

Forward Modelling and Inversion for Survey Design

Kim Frankcombe
ExploreGeo

ASEG Inversion Workshop -Perth 2014

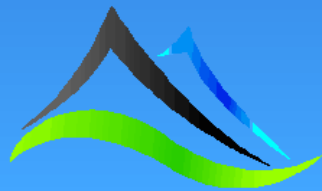

Why do it?

- Modern acquisition systems offer a greater range of options than historically available
- Budgets are tight and users want the maximum bang for their dollars
- Our ability to intuitively interpret data has been surpassed by the computer's ability to massage it. Caveat Emptor!



Case study 1

Array optimisation

Which IP array will provide the best value for money looking for porphyries in Mongolia?

Use the Mongolian porphyry model from previous paper “How Real is Real Section”

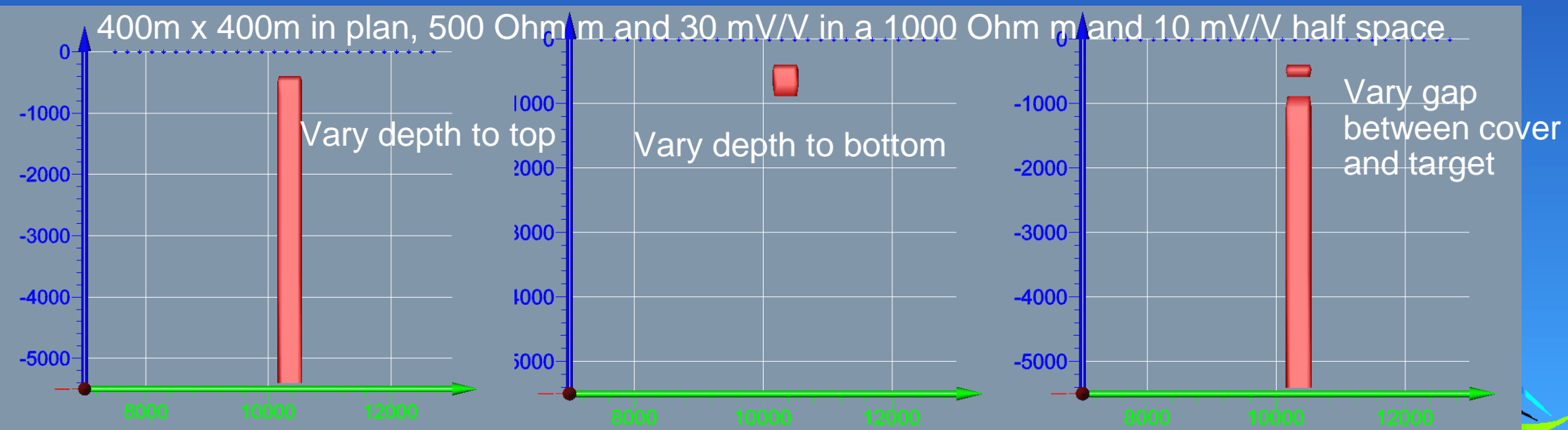

Array Selection

Arrays currently being used to acquire survey data for deep targets

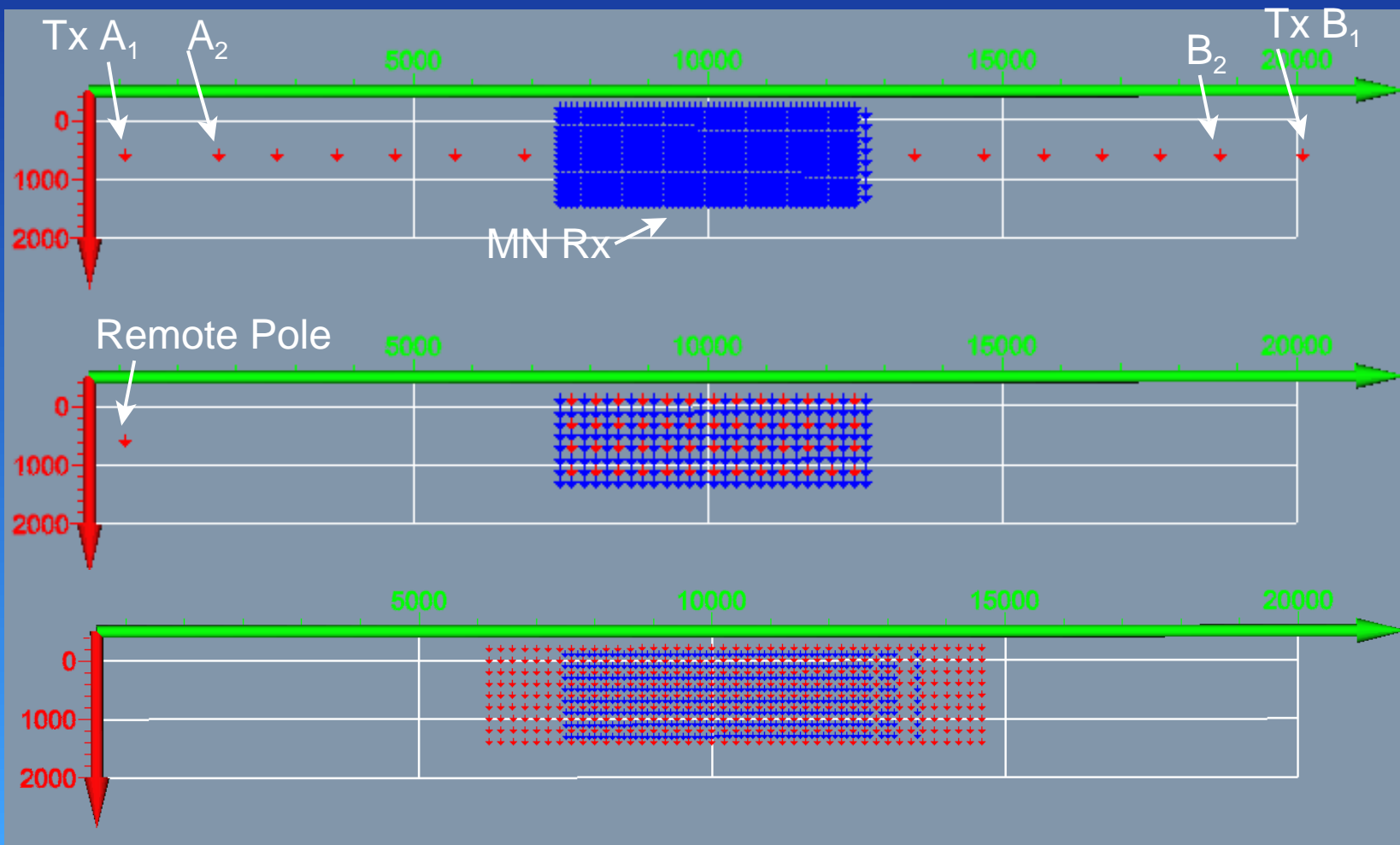

Expanding Gradient Array - "Zeus"

3D Pole-Dipole Array - "Orion"

2.5D Offset Dipole-Dipole or Pole-Dipole Array

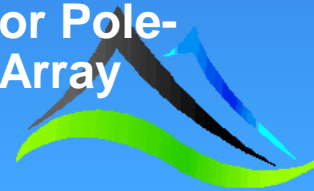

Vary the depth to top

Expanding Gradient 100m Rx dipoles

Colour scale varies between plots

Background 10 mV/V, Target 30 mV/V

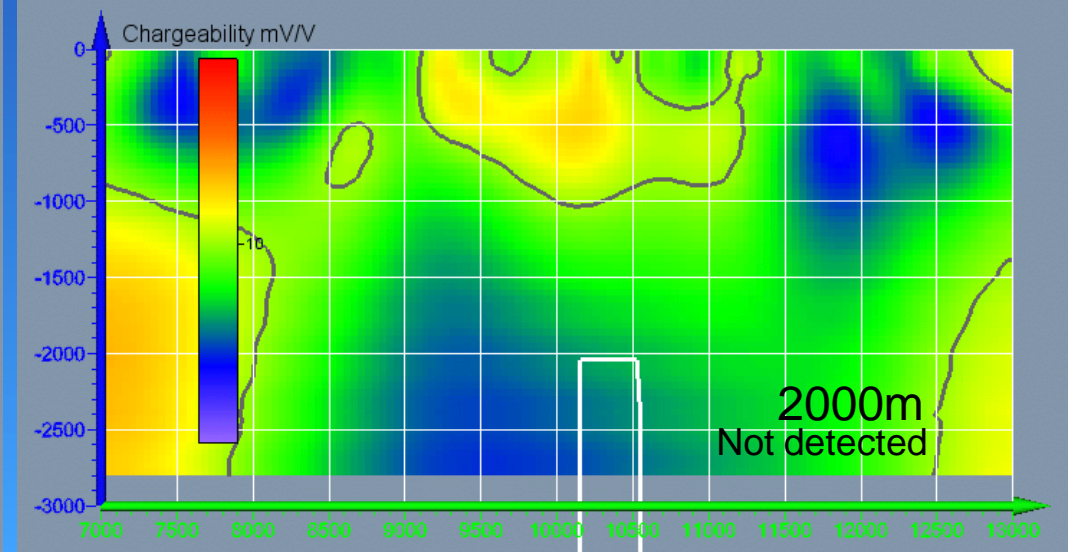
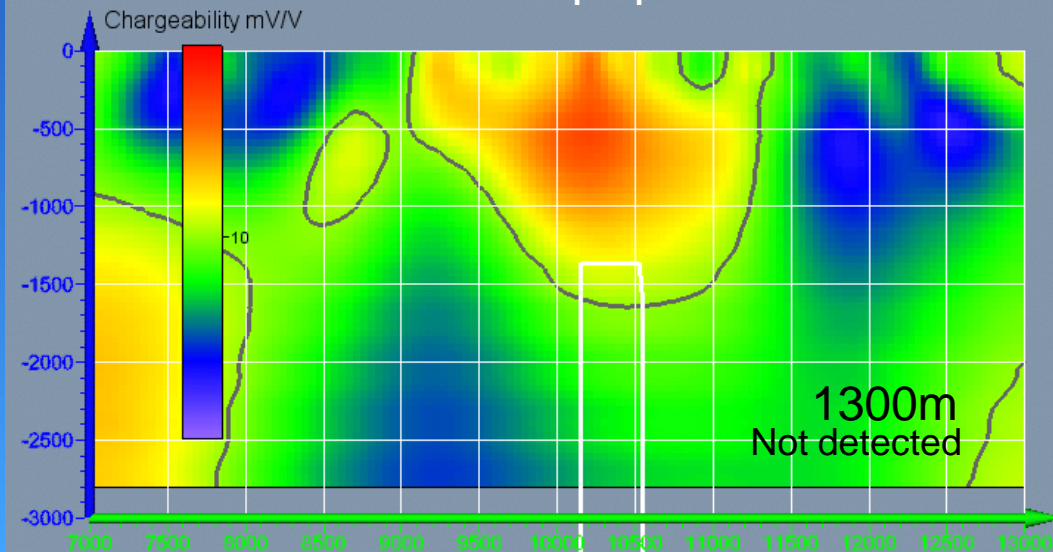
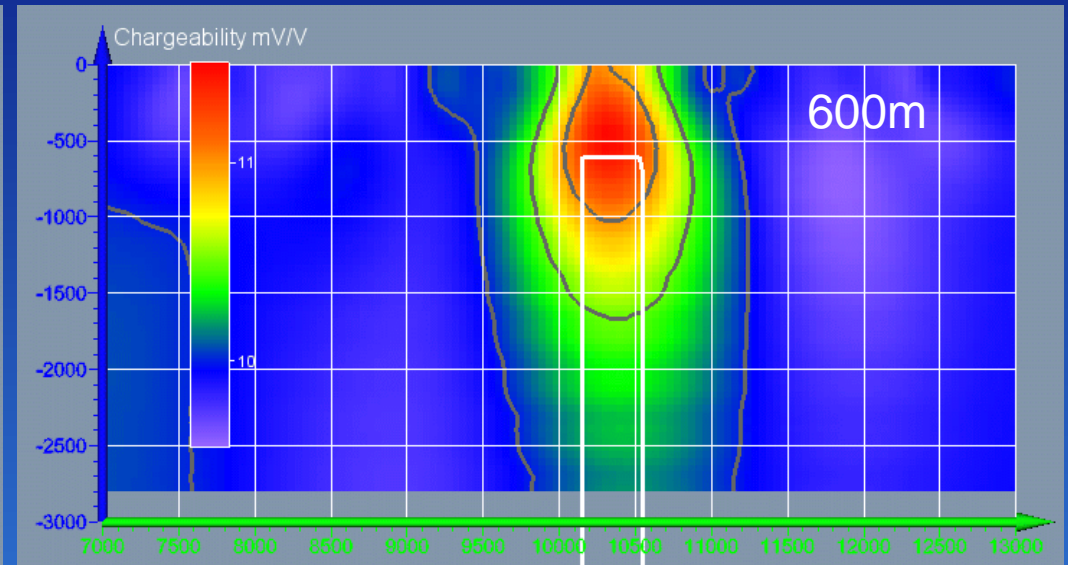
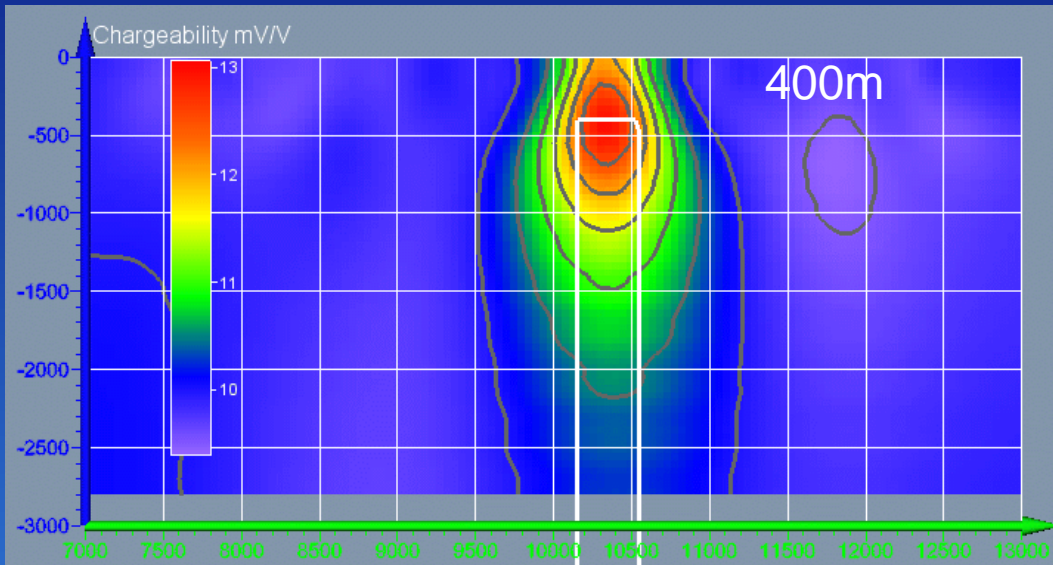

Vary the depth to top

3D Pole-Dipole 200m Rx dipoles

Colour scale varies between plots

Background 10 mV/V, Target 30 mV/V

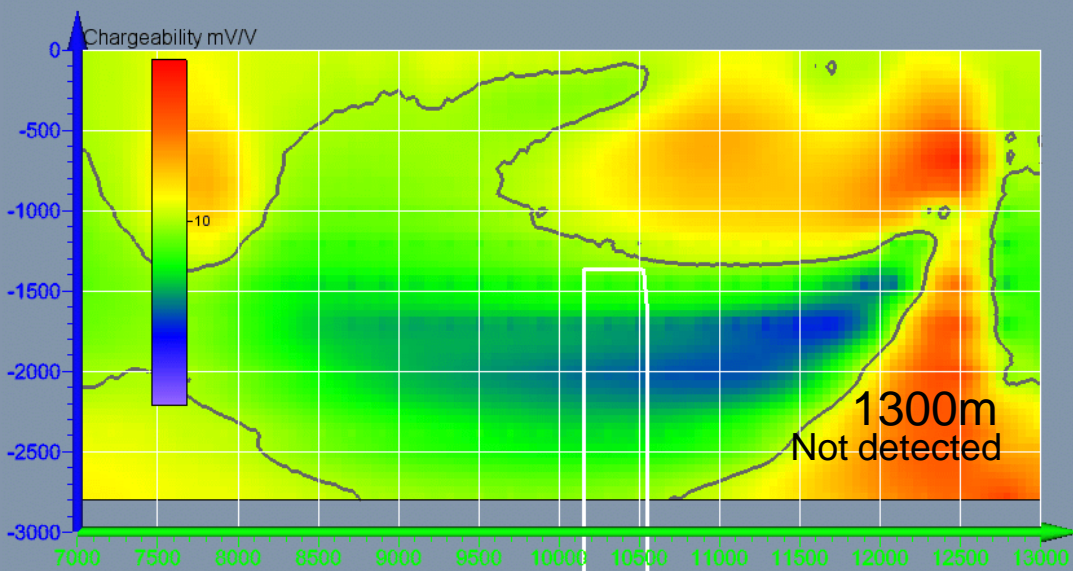
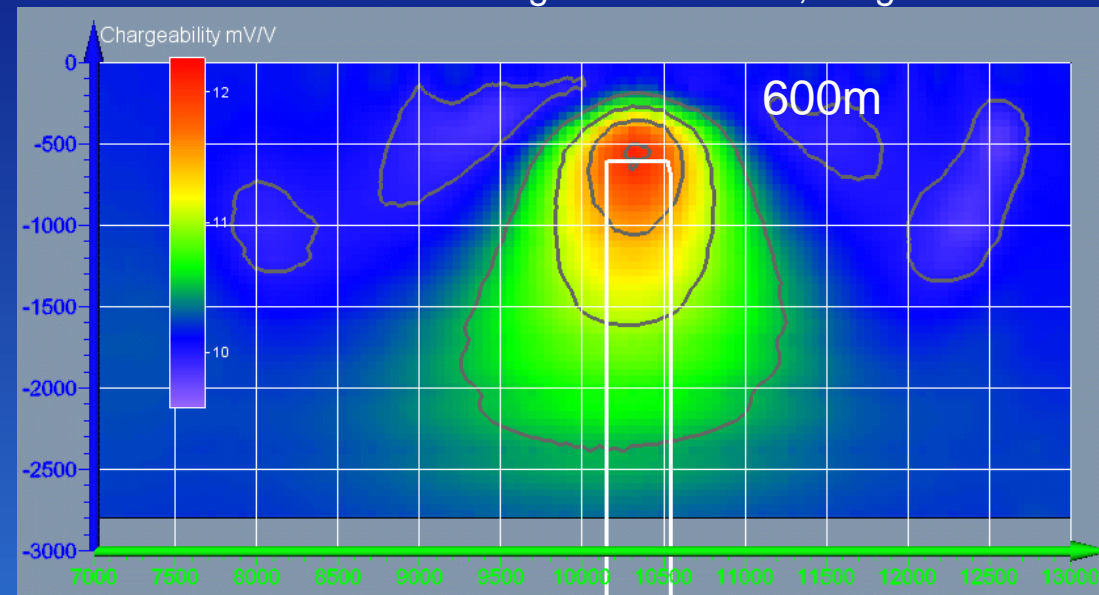
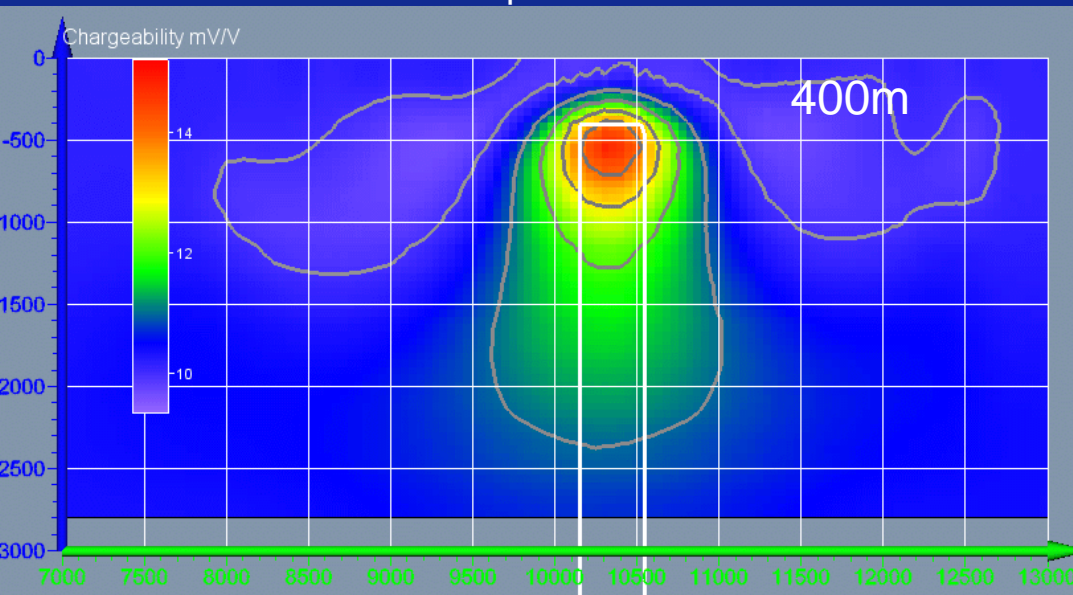

Vary the depth to top

2.5D Offset Dipole-Dipole 100m Rx dipole, 200m Tx dipole

Colour scale varies between plots

Background 10 mV/V, Target 30 mV/V

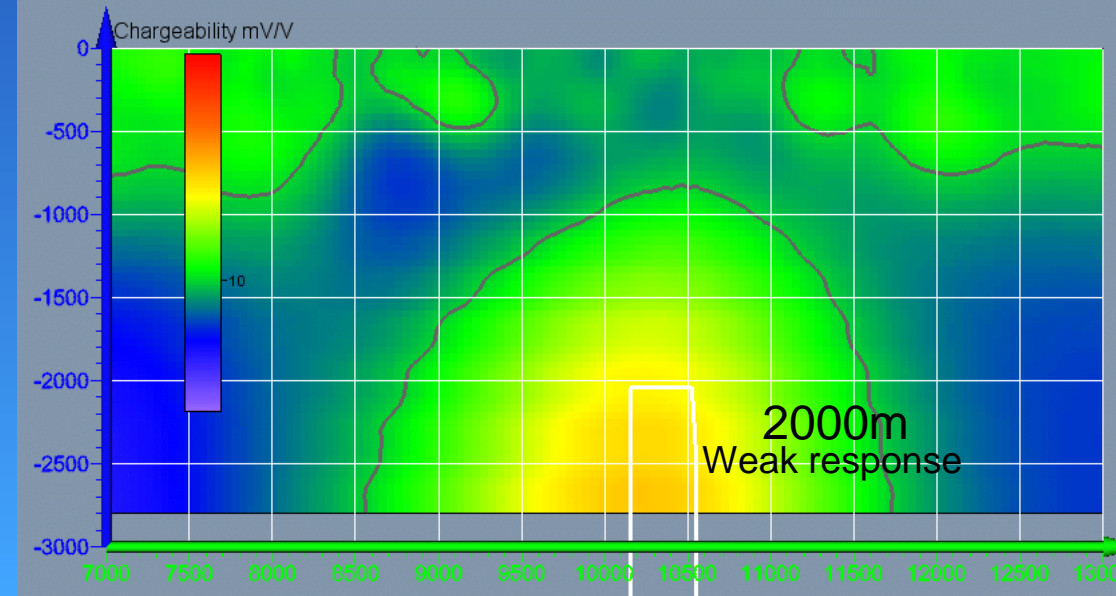
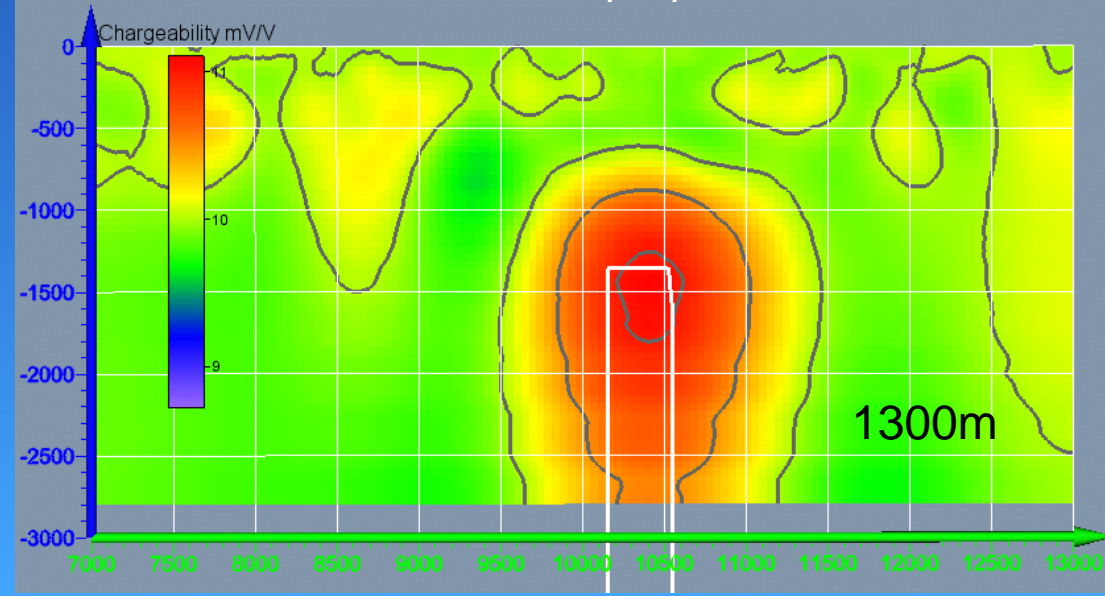
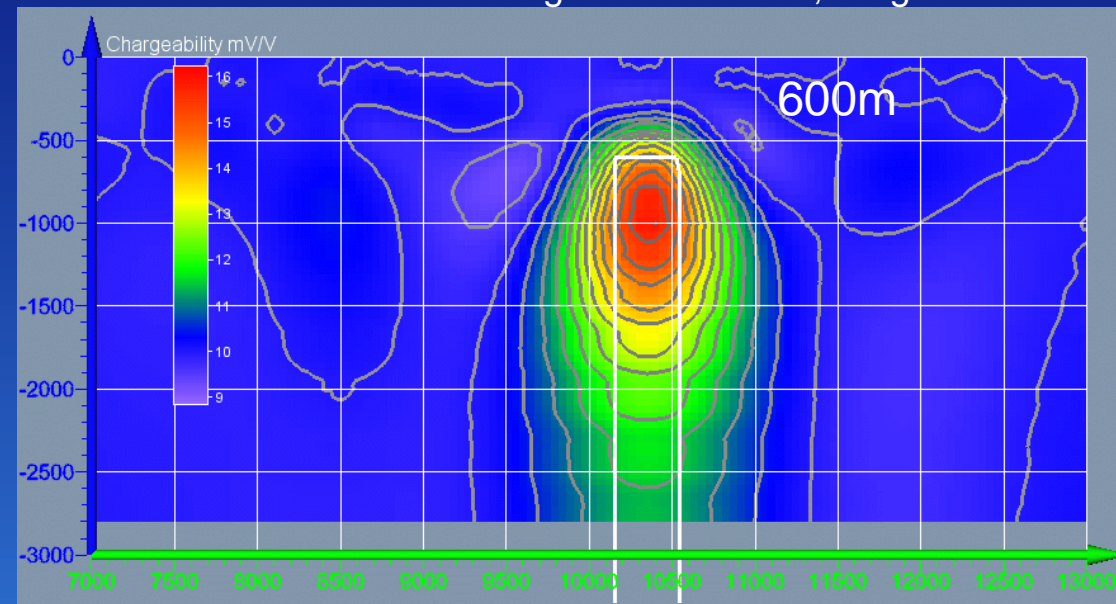
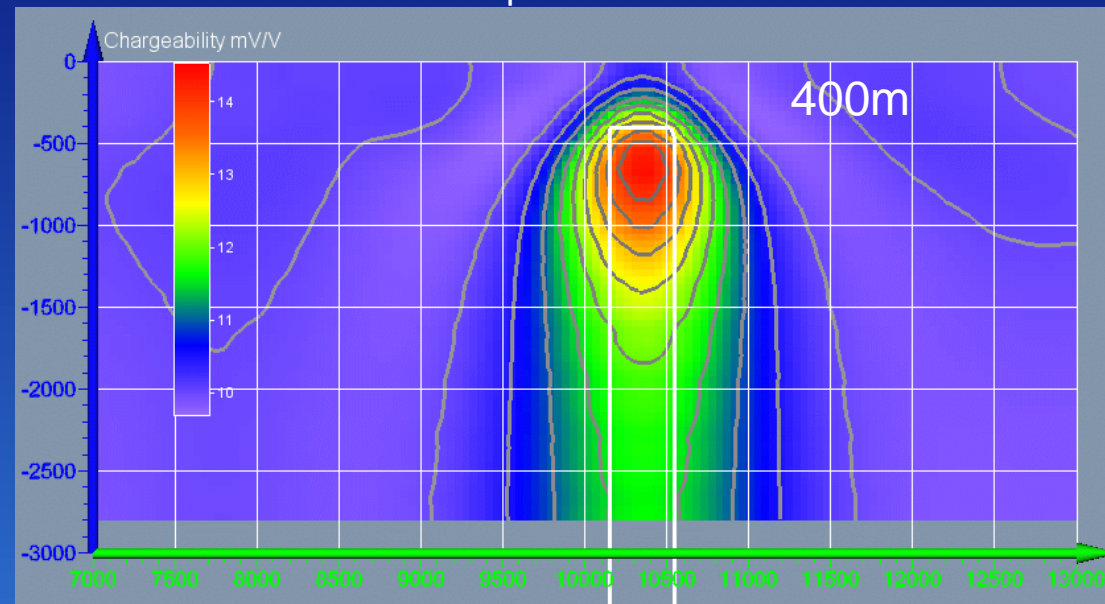

Vary the depth to bottom

Expanding Gradient 100m Rx dipoles

Colour scale varies between plots

Background 10 mV/V, Target 30 mV/V

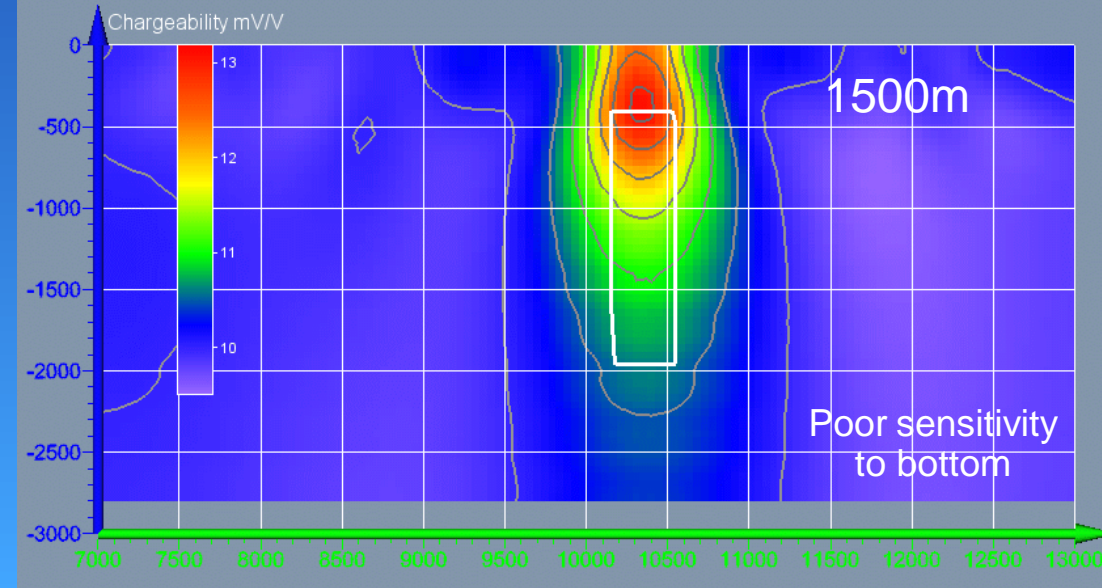
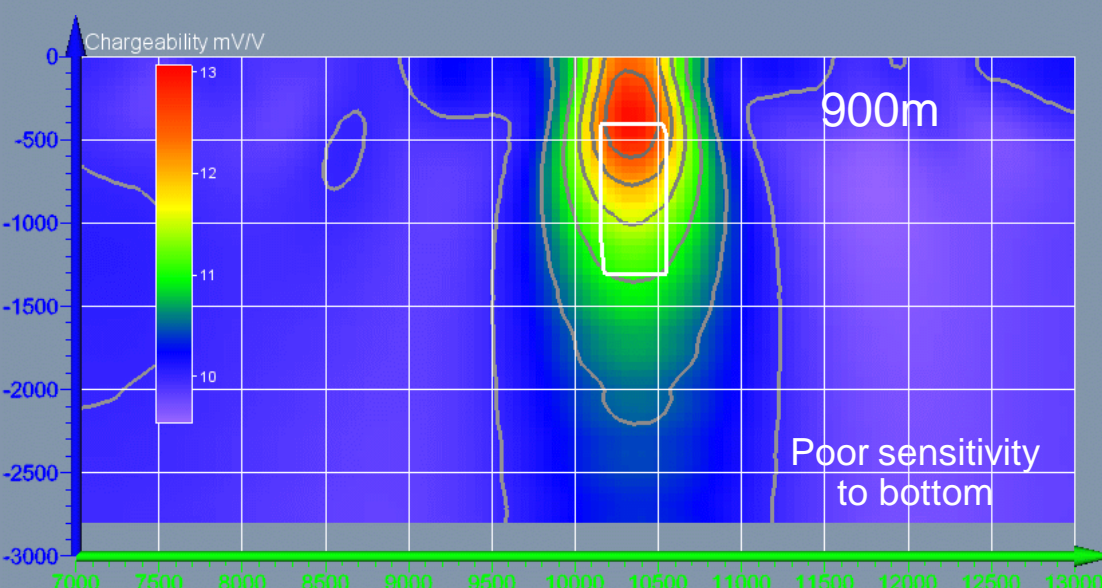
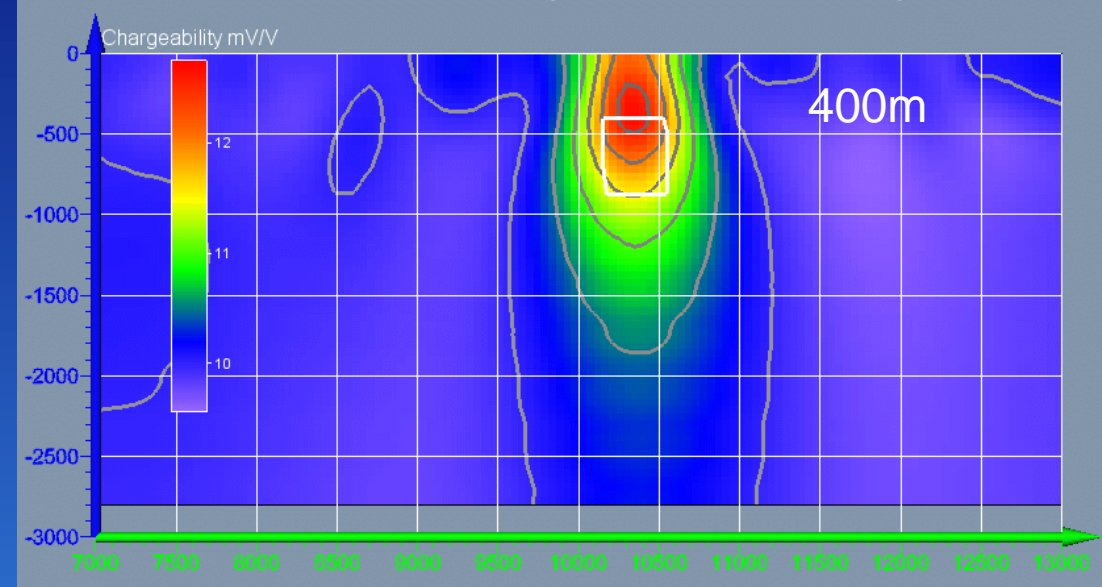
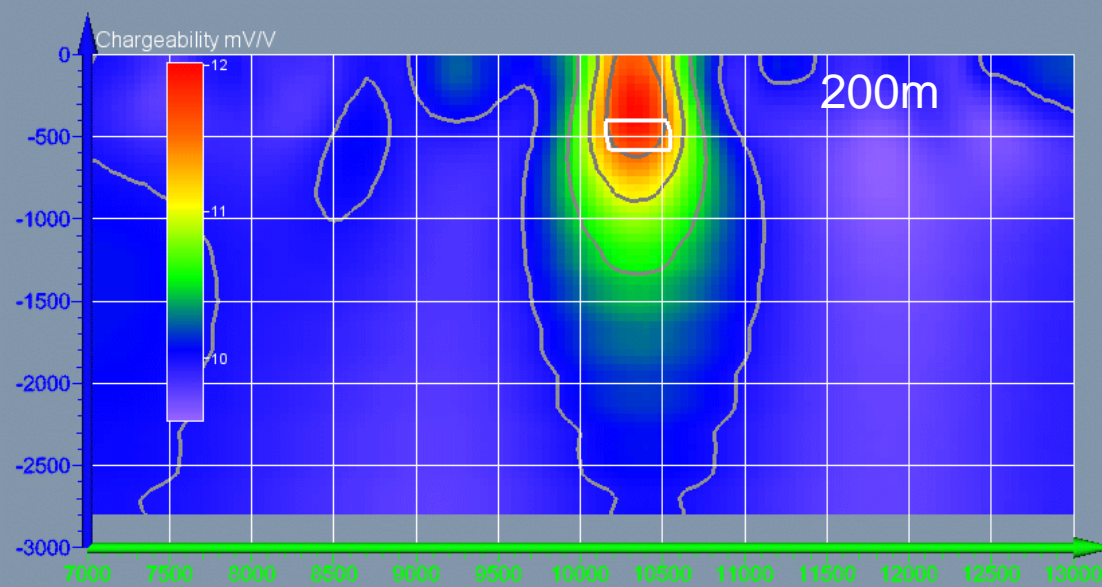

Vary the depth to bottom

3D Pole-Dipole 200m Rx dipoles

Colour scale varies between plots

Background 10 mV/V, Target 30 mV/V

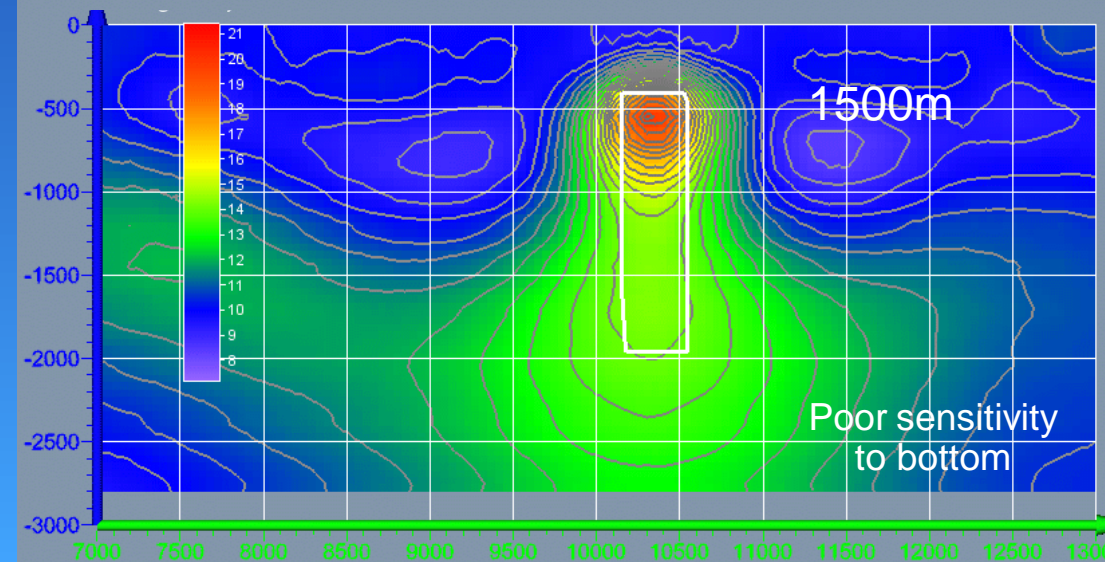
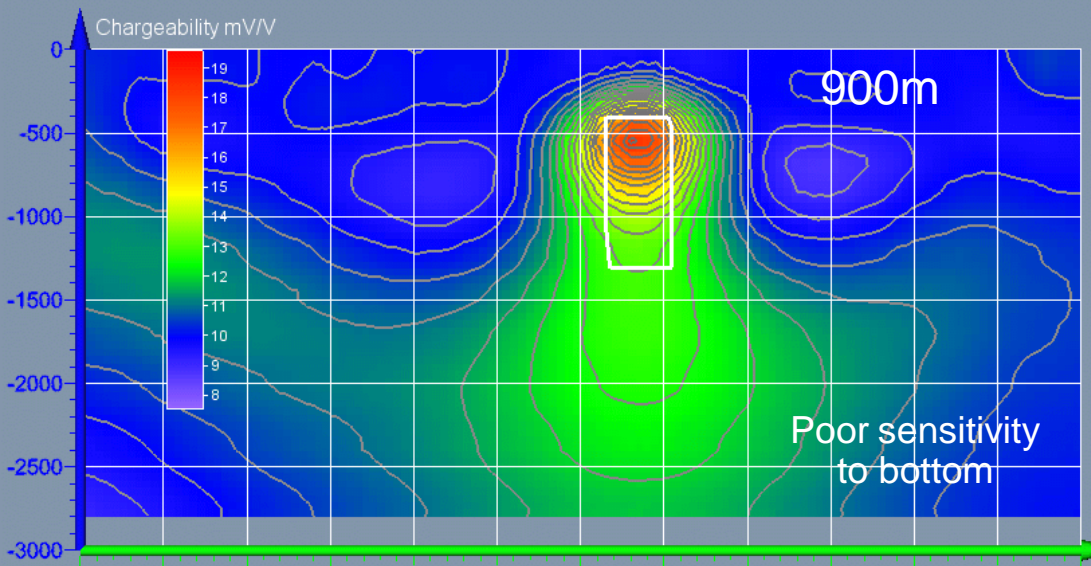
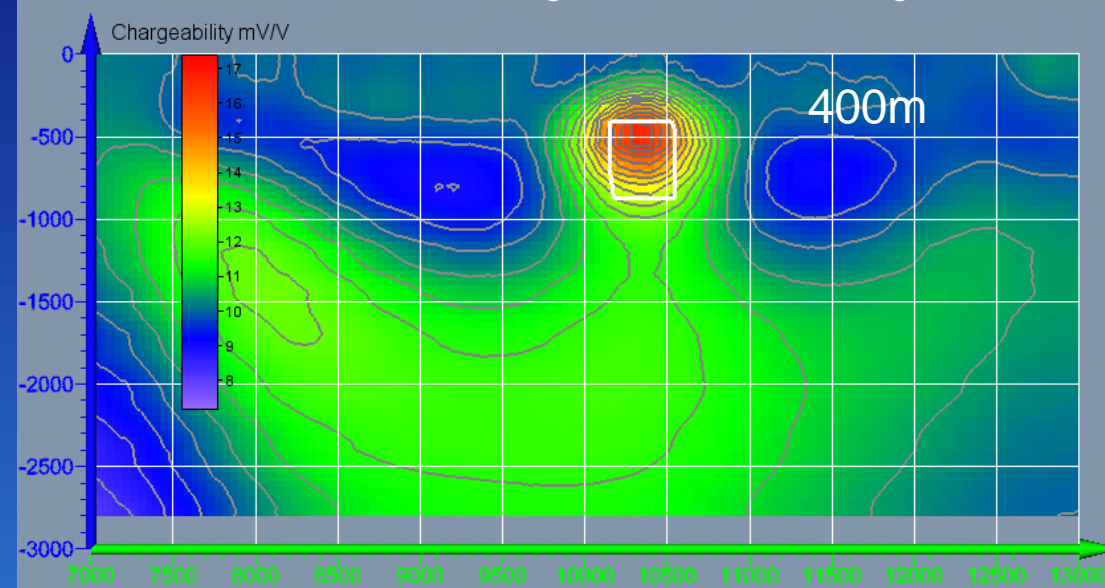
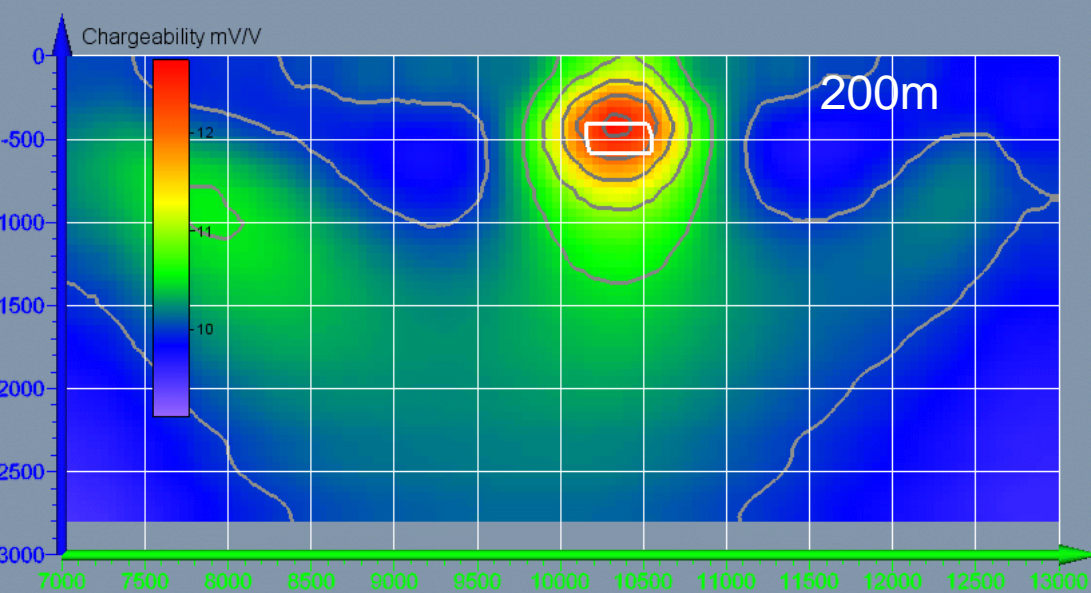

Vary the depth to bottom

2.5D Offset Dipole-Dipole 100m Rx dipole, 200m Tx dipole

Colour scale varies between plots

Background 10 mV/V, Target 30 mV/V

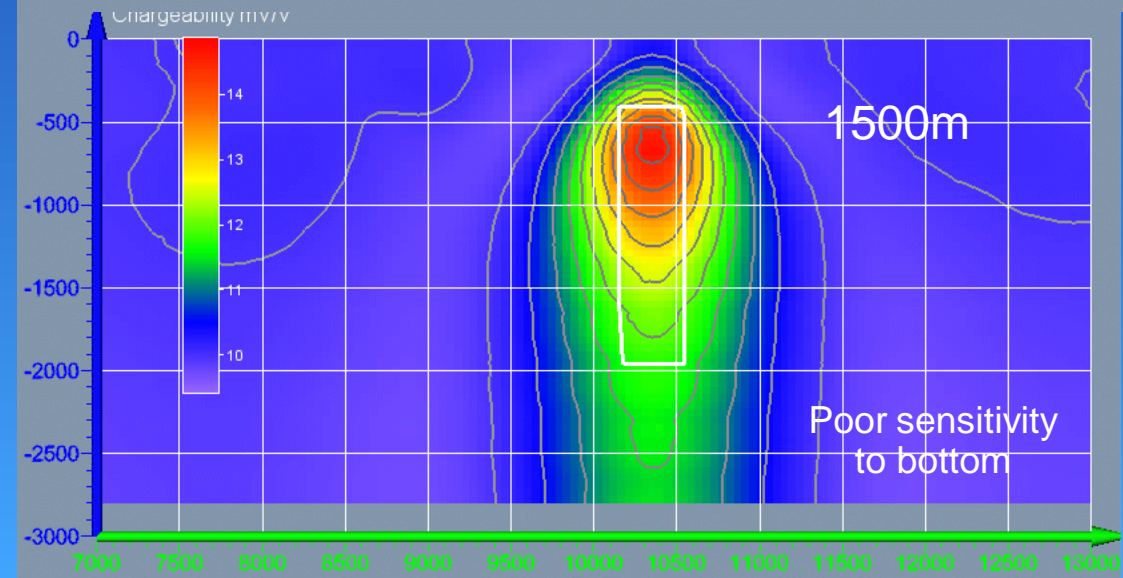
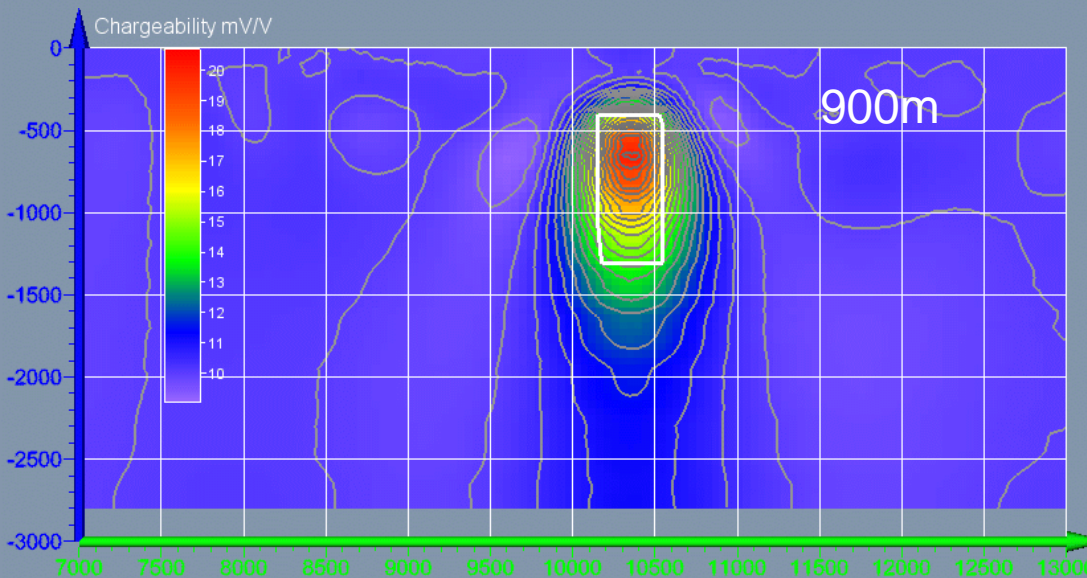
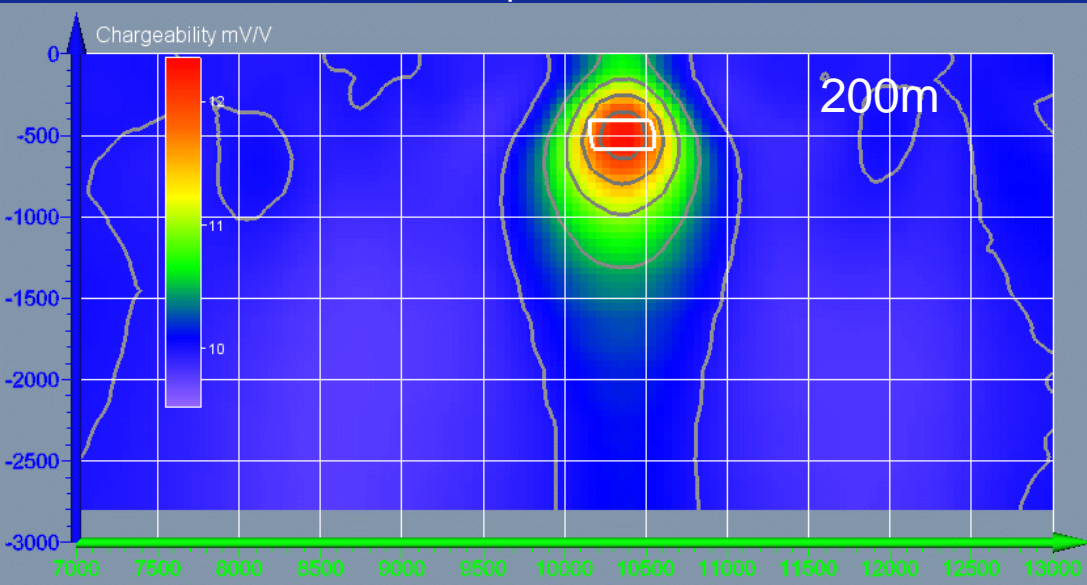

Vary the distance below a screen

Expanding Gradient 100m Rx dipoles

Colour scale varies between plots

Background 10 mV/V, Target 30 mV/V

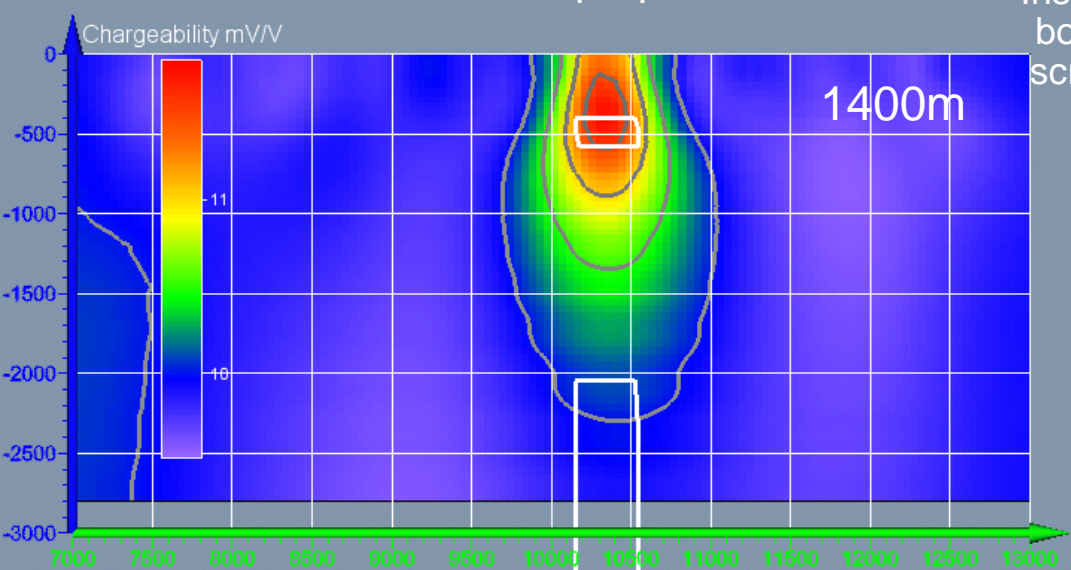
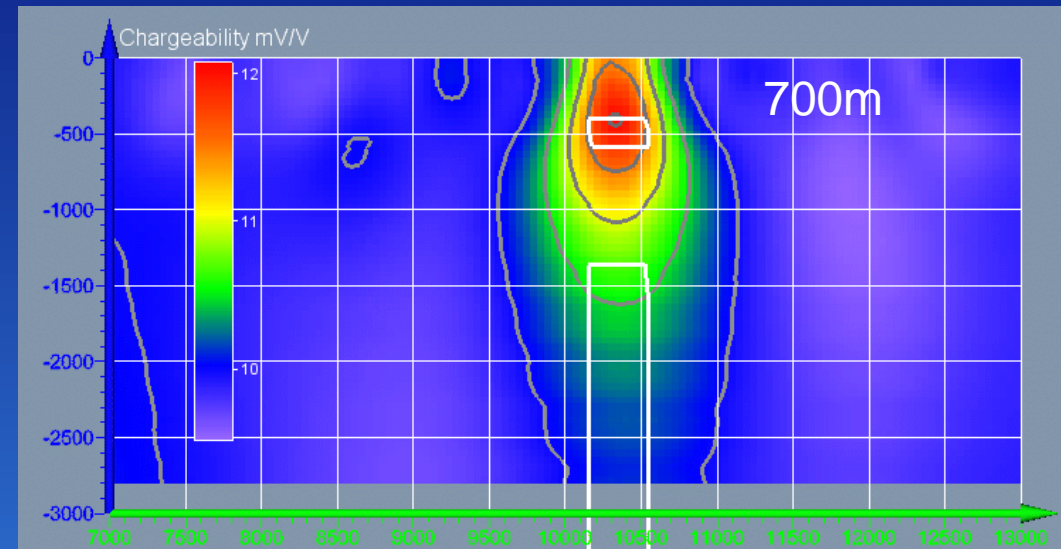
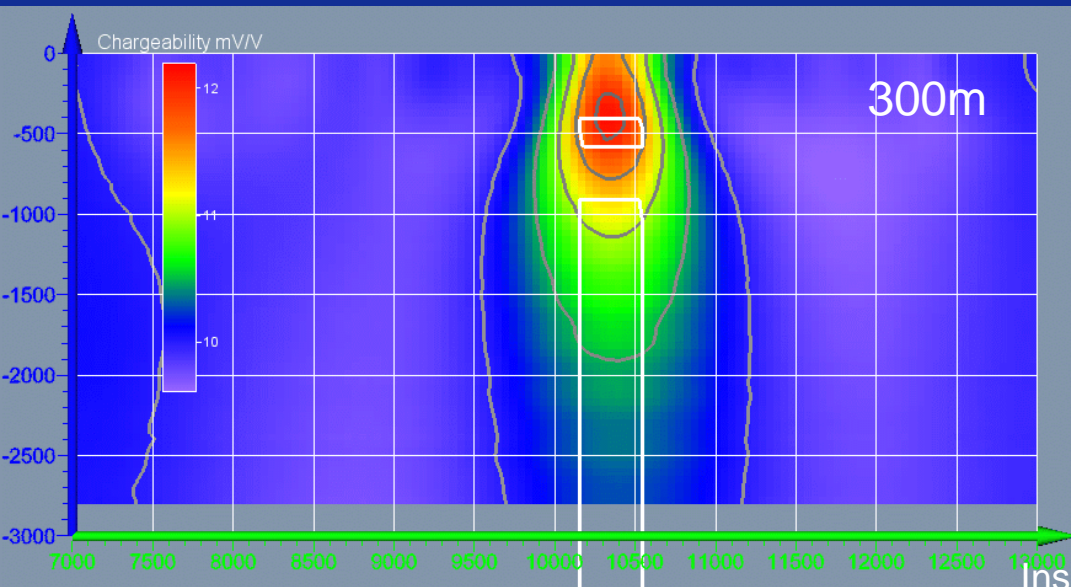

Insensitive to body below screen in all cases

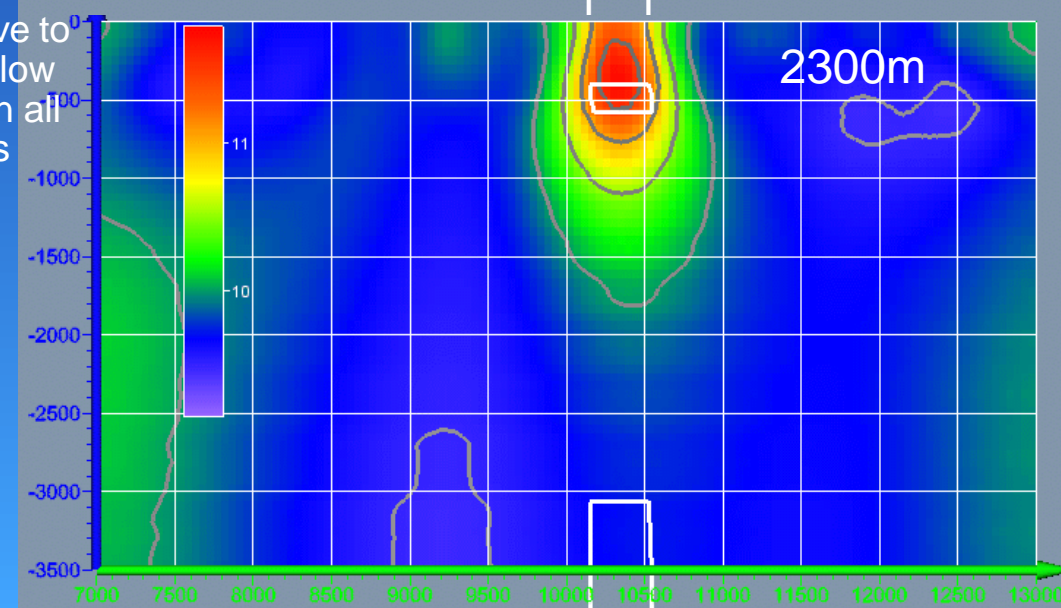

Vary the distance below a screen

3D Pole-Dipole 200m Rx dipoles

Colour scale varies between plots

Background 10 mV/V, Target 30 mV/V

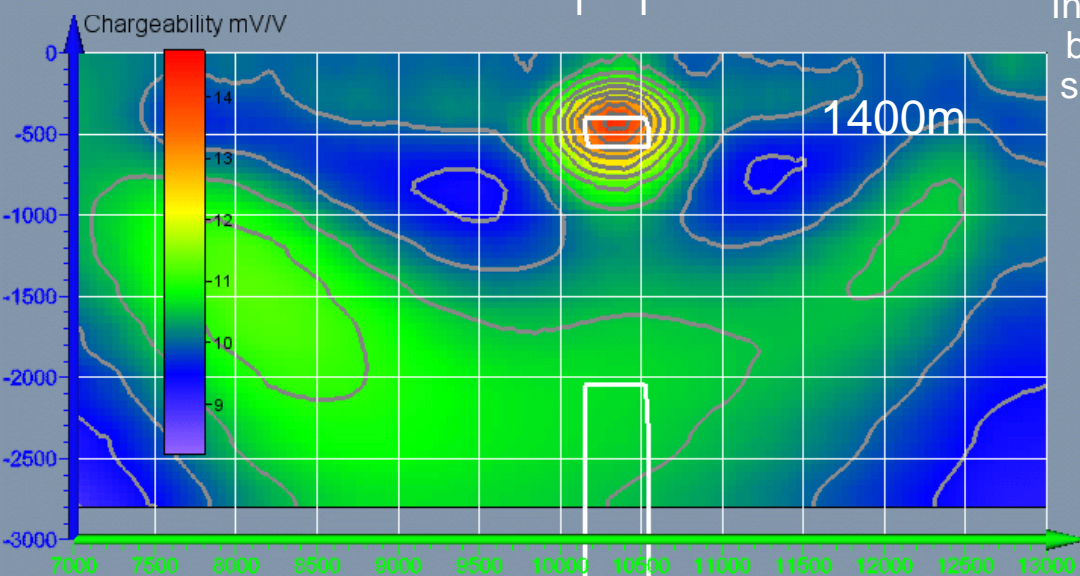
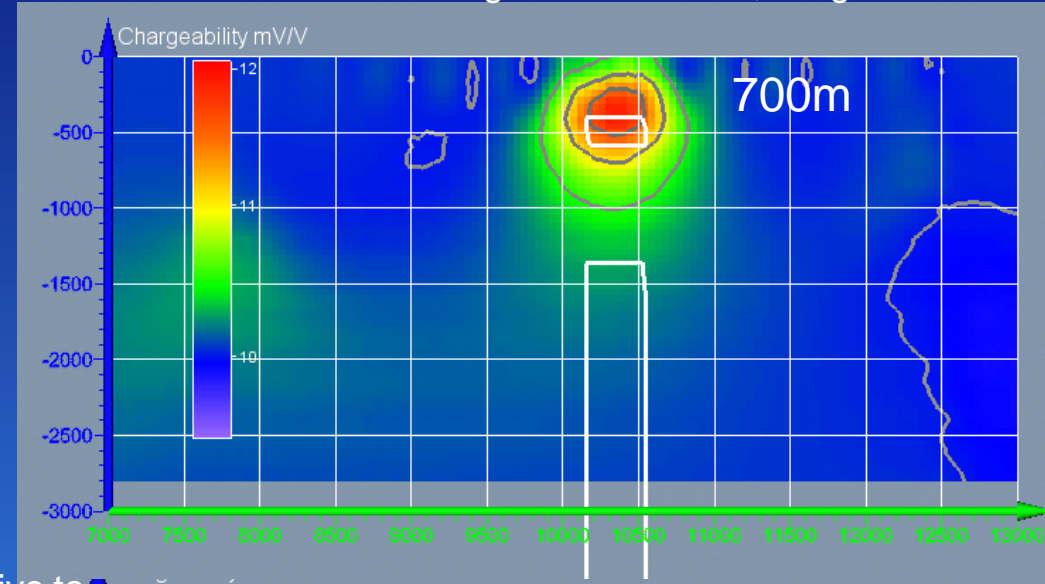
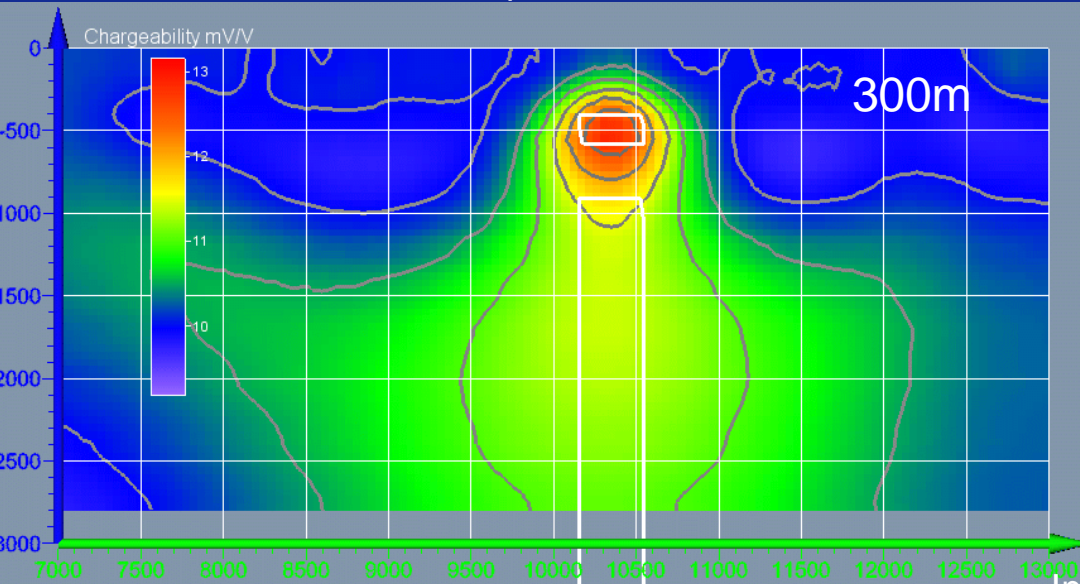

Insensitive to
body below
screen in all
cases

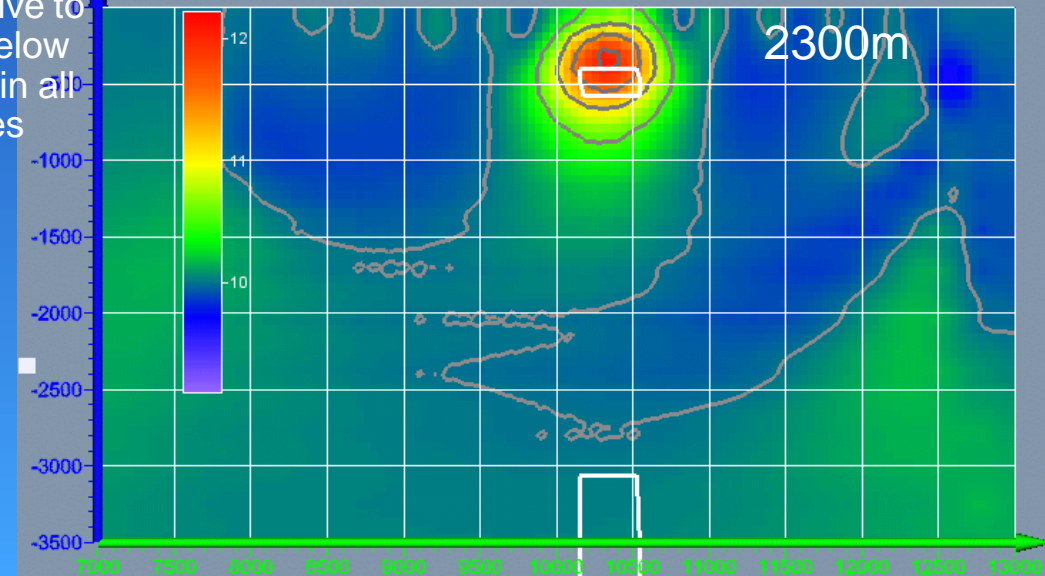

Vary the distance below a screen

2.5D Offset Dipole-Dipole 100m Rx dipole, 200m Tx dipole

Colour scale varies between plots

Background 10 mV/V, Target 30 mV/V

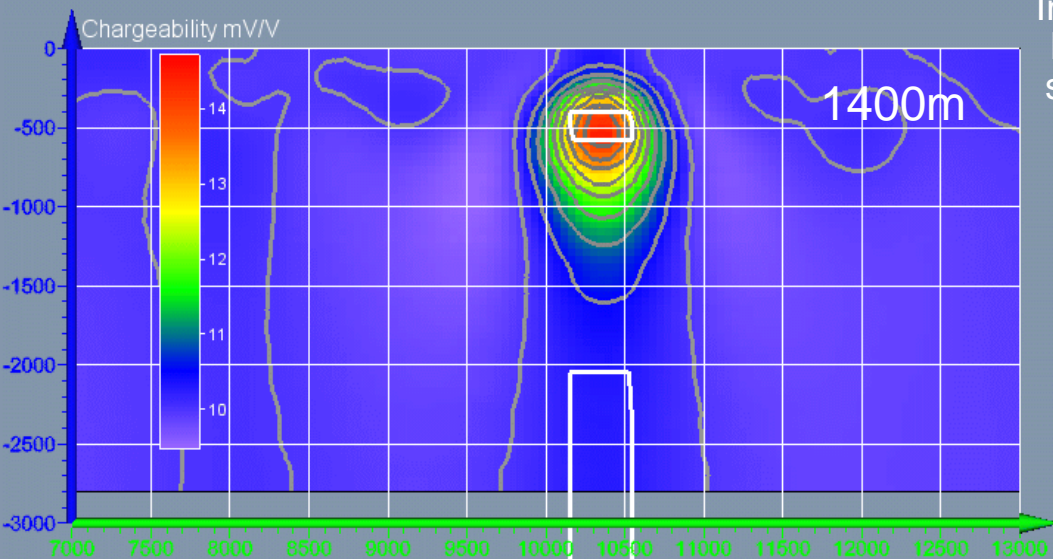
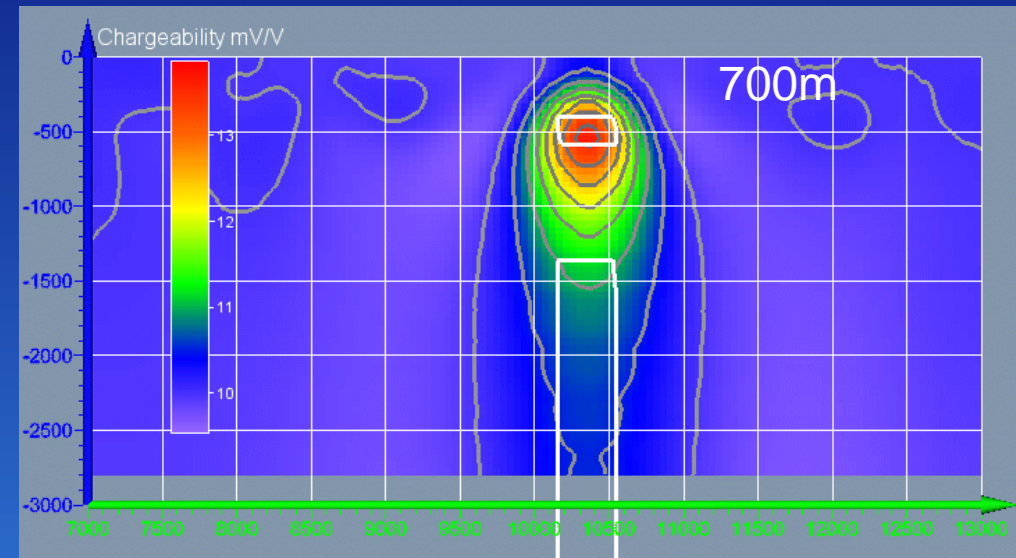
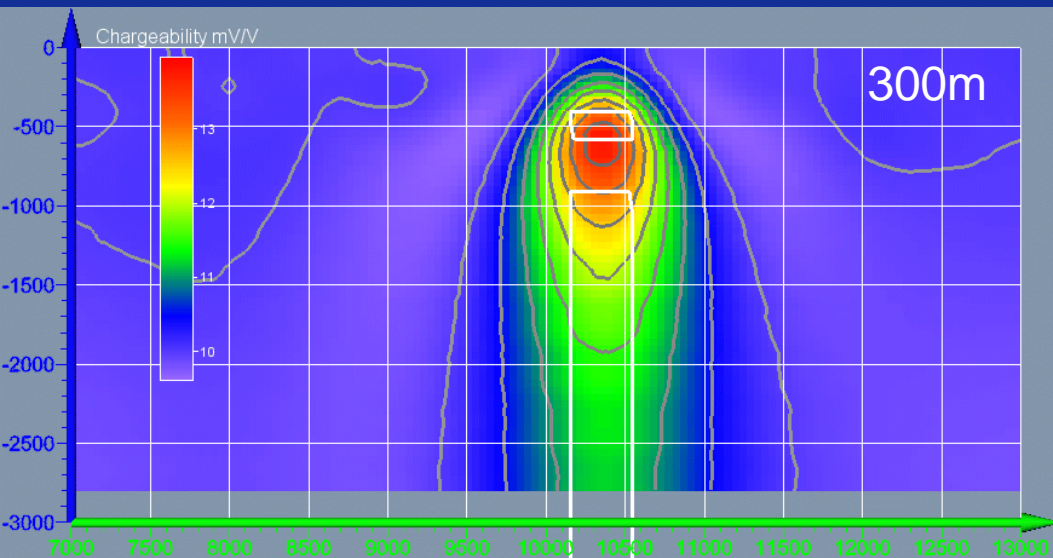

Inensitive to
body below
screen in all
cases



Mapping dip

Body dips to the left

Colour scale varies between plots

Background 10 mV/V, Target 30 mV/V

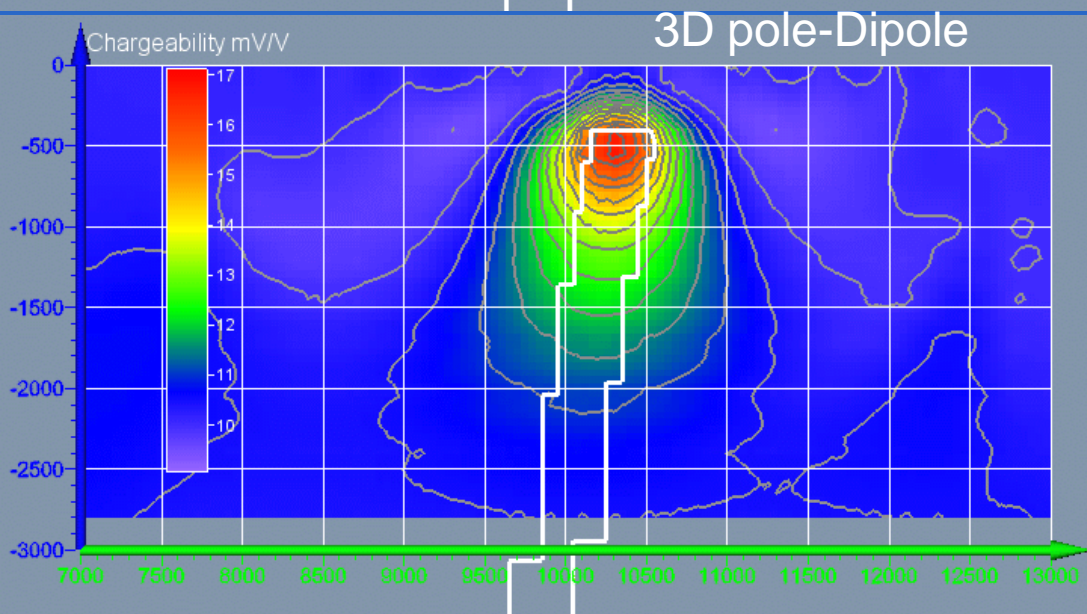
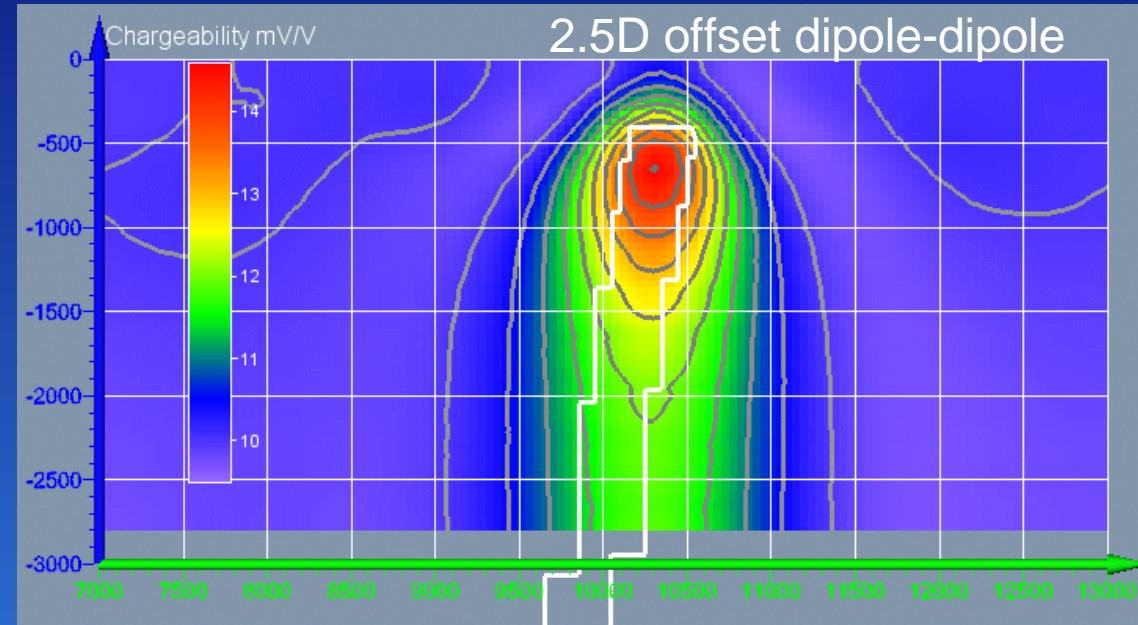
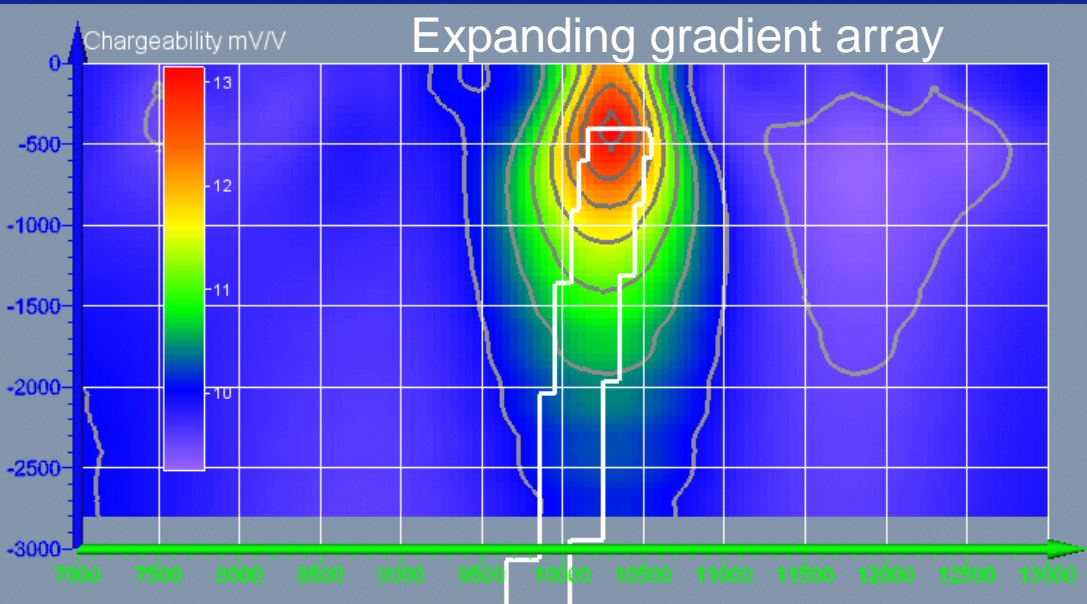

All arrays are insensitive to dip

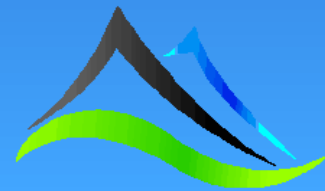

Conclusions

- Even using 20km current dipoles the gradient array is only seeing the top of the body and then only to <1300m - MN is overriding AB
- Using a 10km current dipole the 3D pole-dipole array is seeing the upper part of the body but not seeing to 1300m - MN is overriding AB
- None of the arrays do a good job of seeing a target below a screen
- None of the arrays do a good job of mapping dip at depth



WHY?



Sensitivity

See appendix - Sensitivity changes with electrode spacing

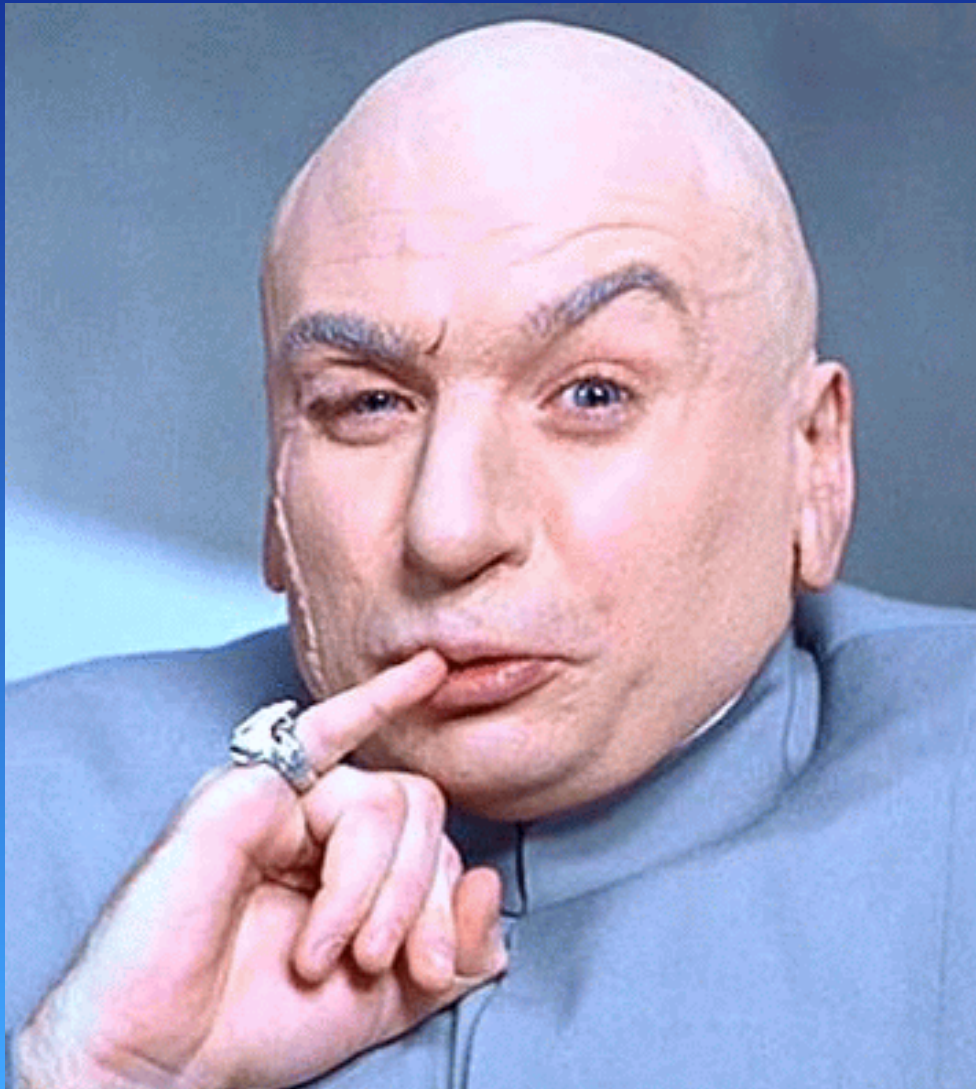

How can we use this to our advantage? - See appendix.

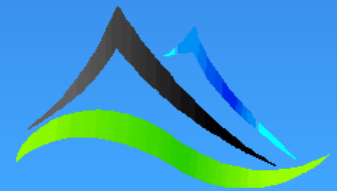

1D resistivity profiling to ERI

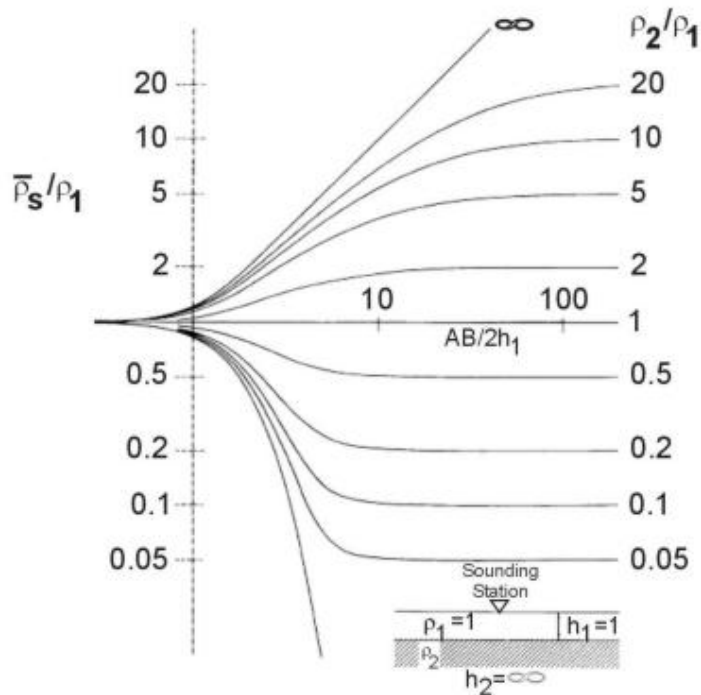

The near surface geophysicists have gone from simple 1D soundings to electrical tomography by using multi-resolution arrays with varying MN, AB and n.

From 10 readings to 10,000 over the same site

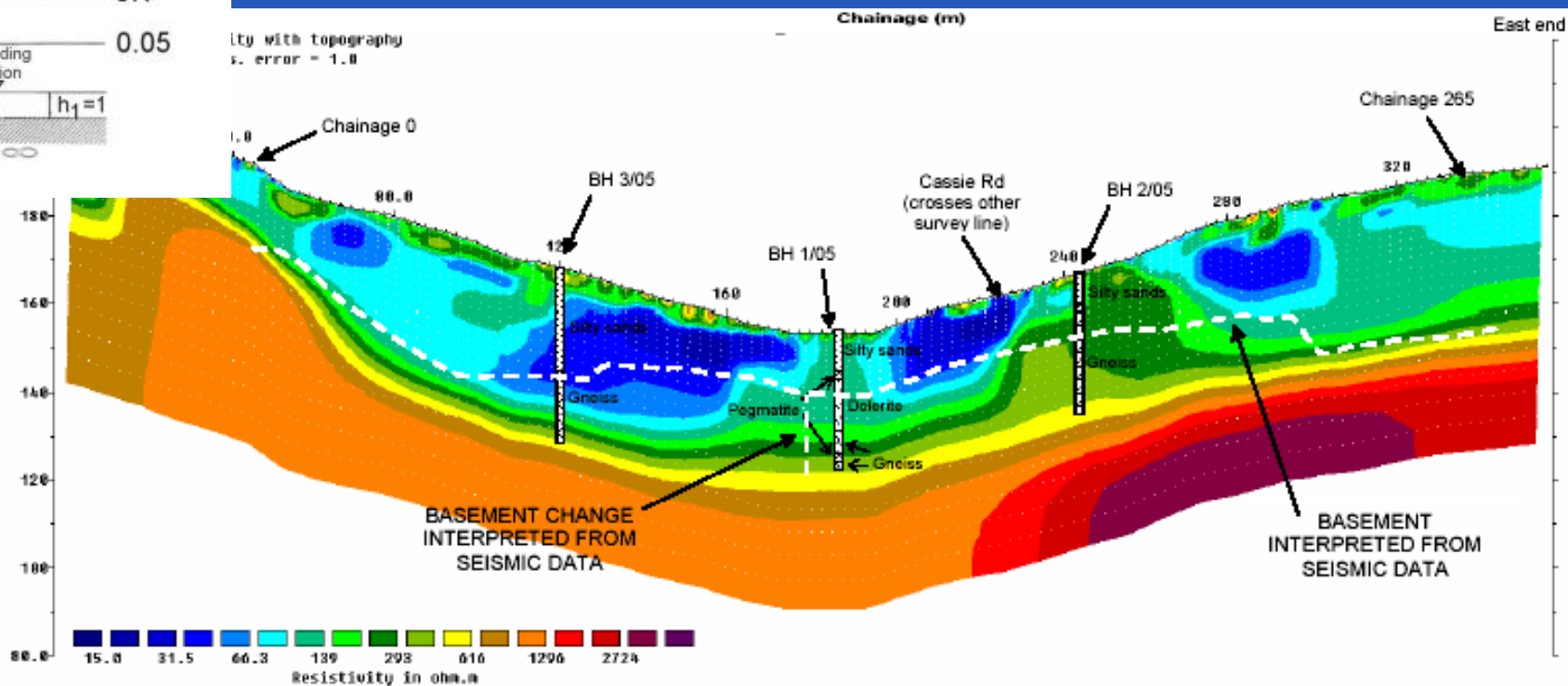

Case Study 2

Array selection

Manto style mineralisation

Resistivity section

Chargeability section

Chargeability Plan

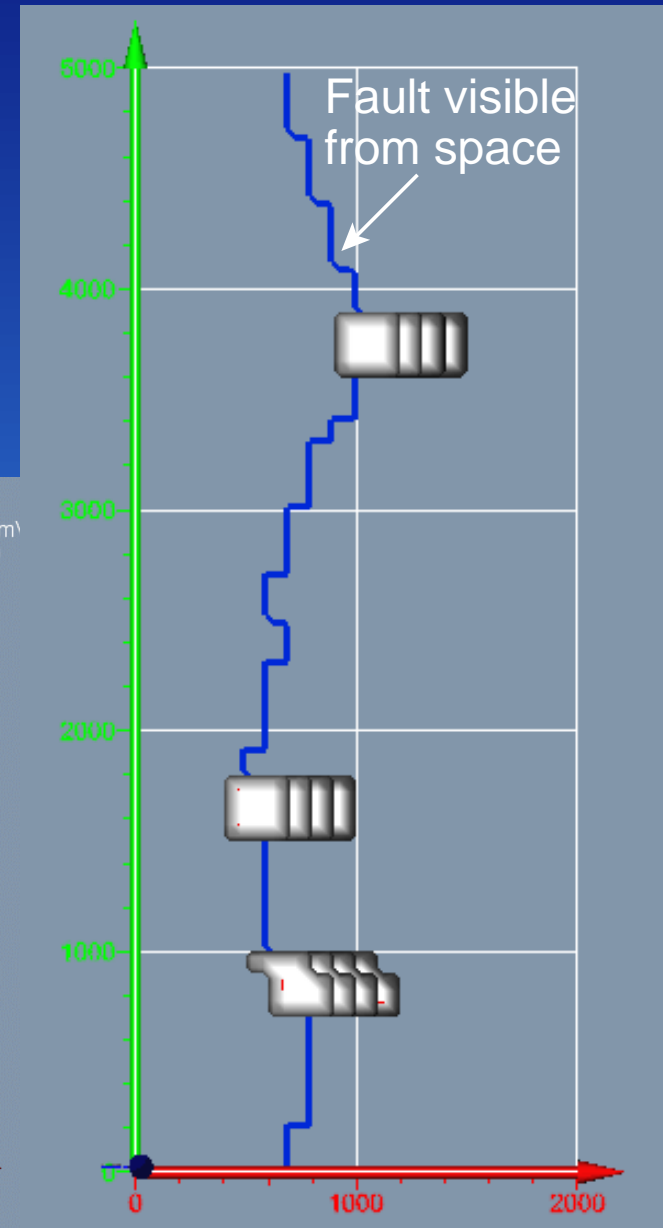
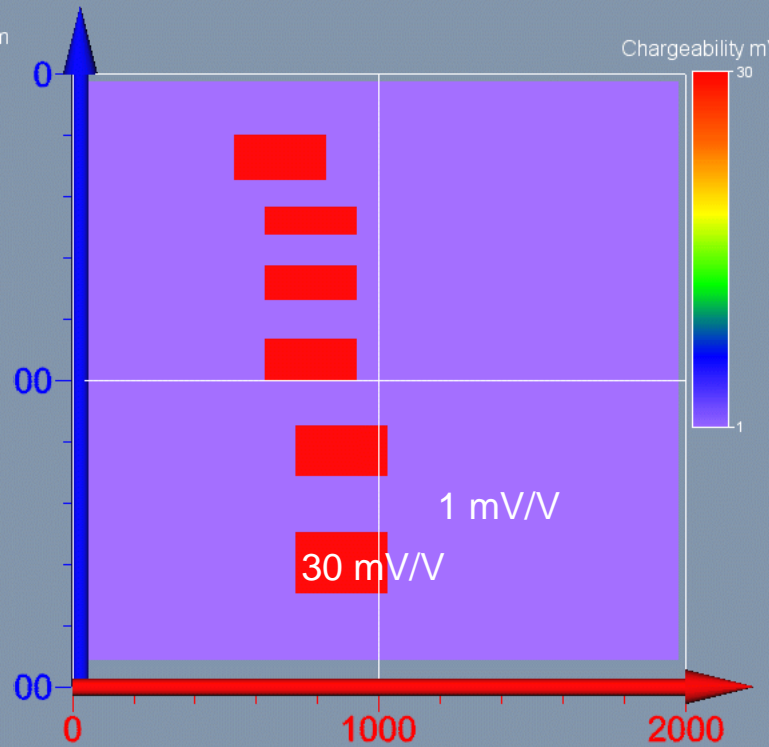
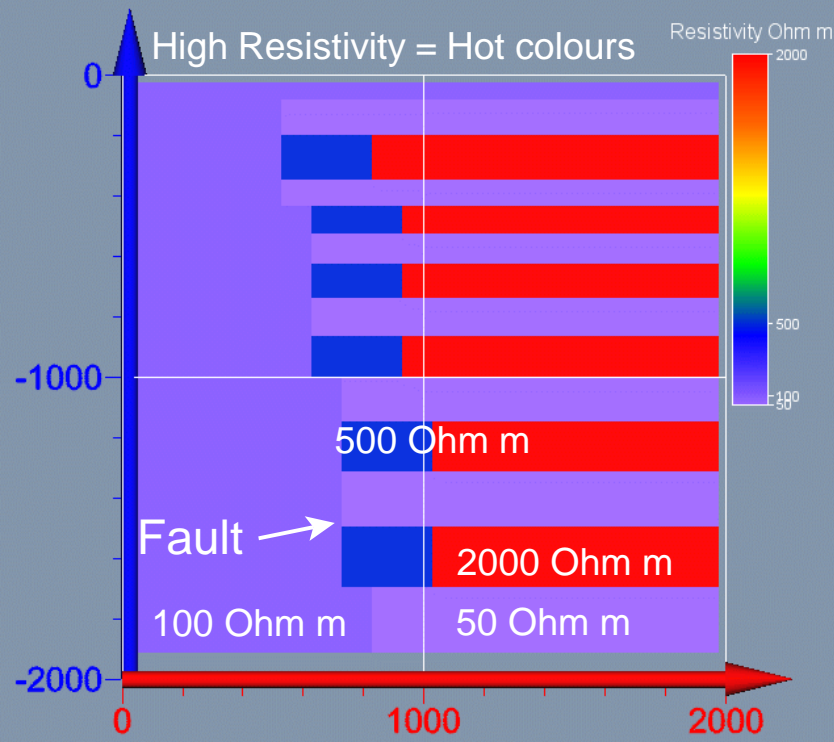

Old Style Contractor's Premium Selection

2D DIPOLE-DIPOLE

Line spacing matches target size

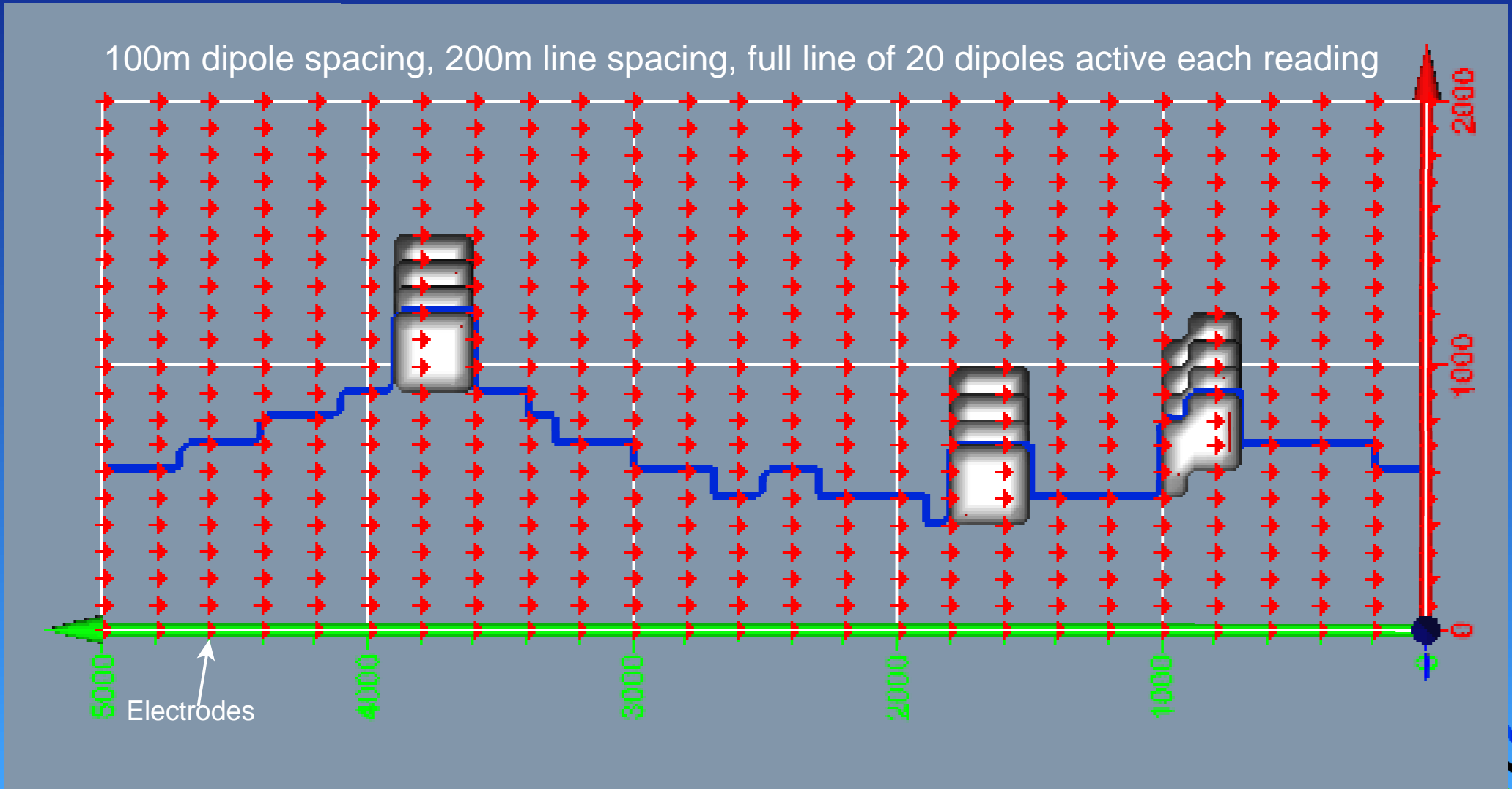

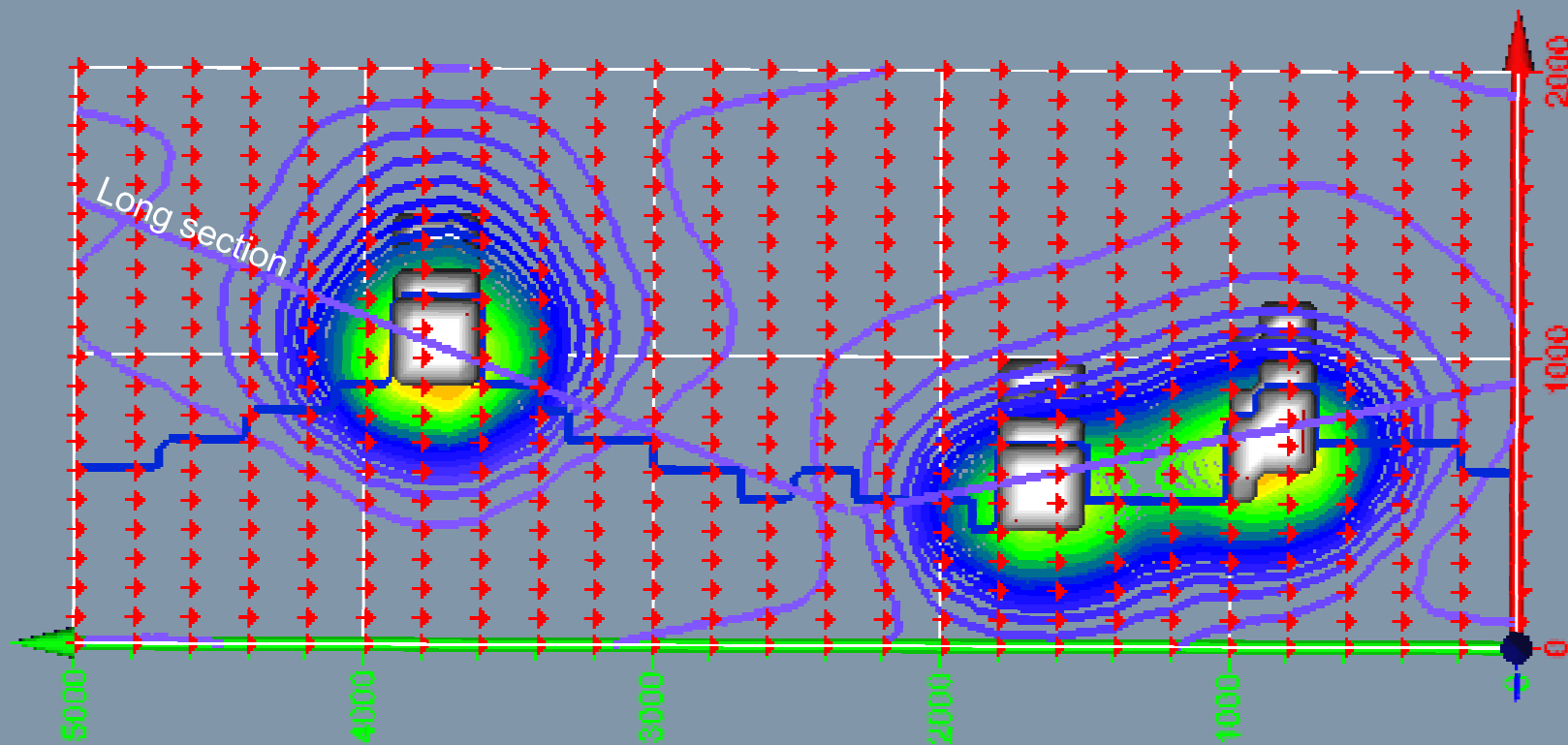

3D inversion - Plan view of contour slice through maximum response

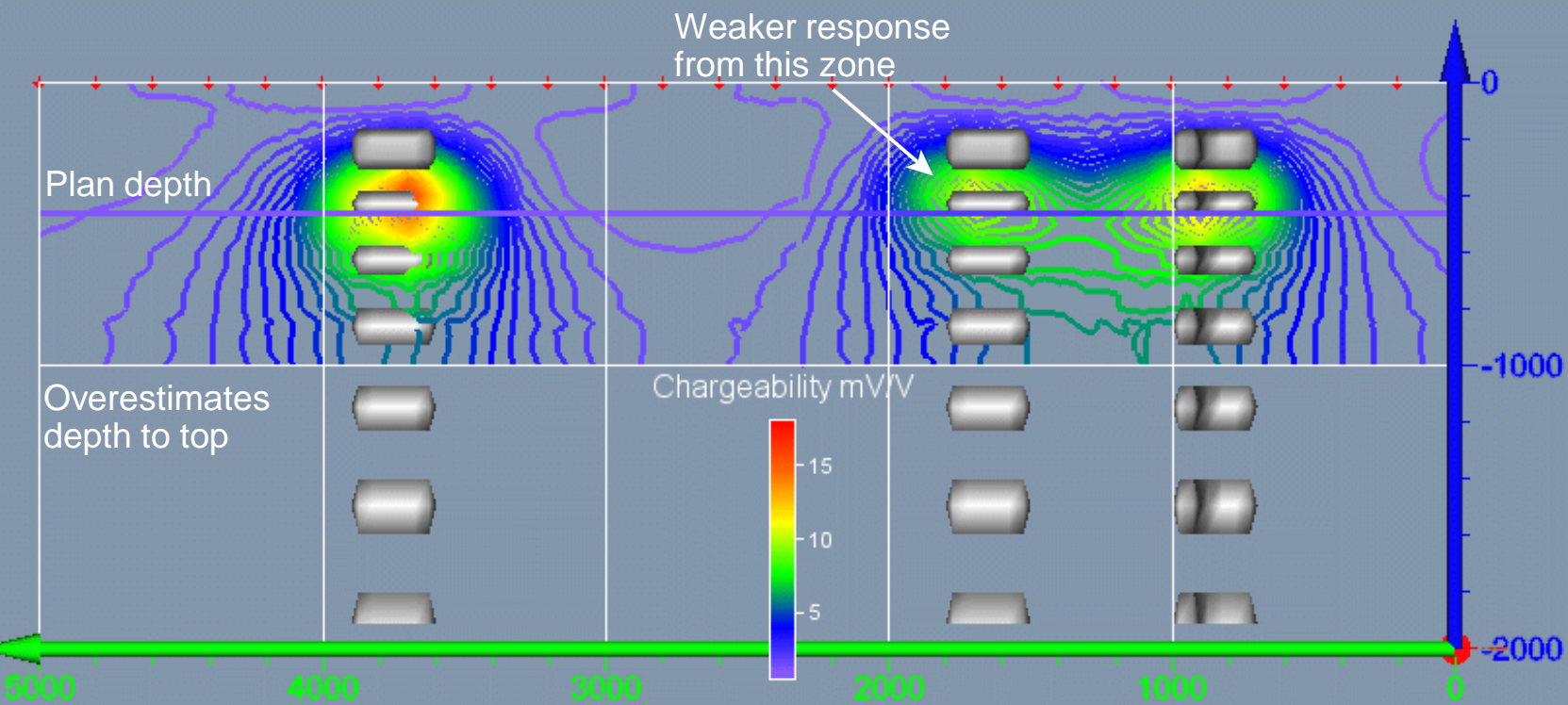

3D inversion - Bent long section view of contours through body centres

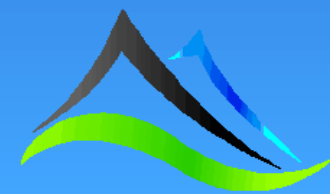

New Style Contractor's Premium Selection

3D POLE-DIPOLE

Arguably too small a dipole size
for this target

100m dipole spacing, 200m line spacing, full array of 1000 dipoles active each reading

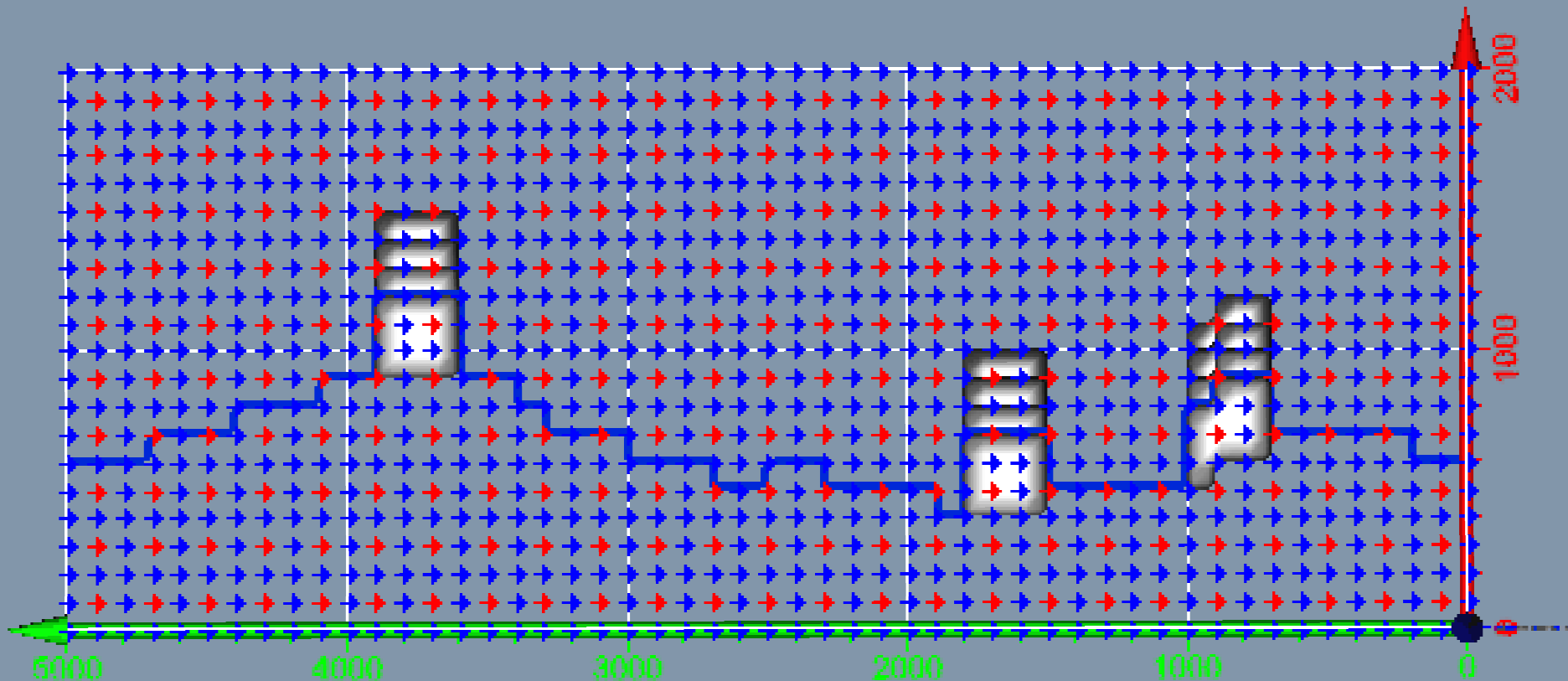

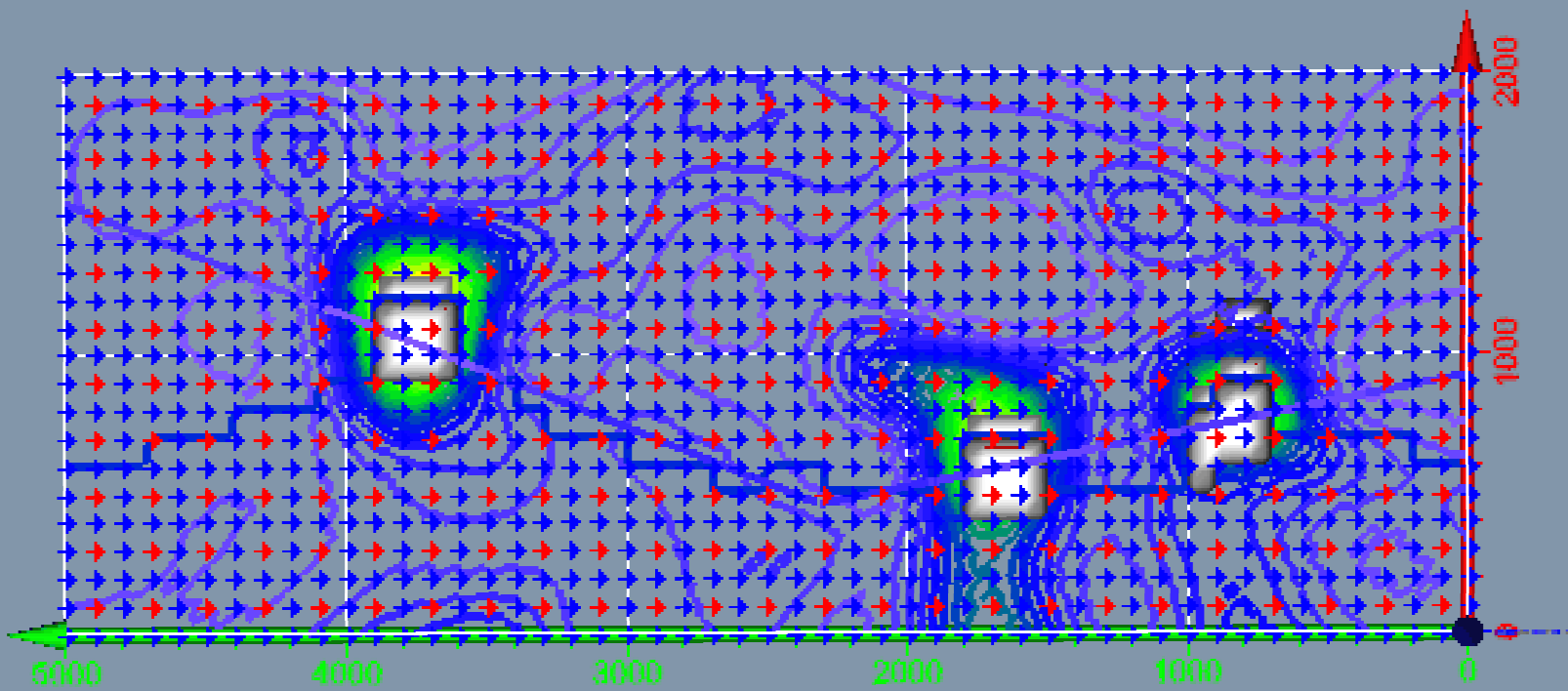

Plan view of contour slice through maximum response

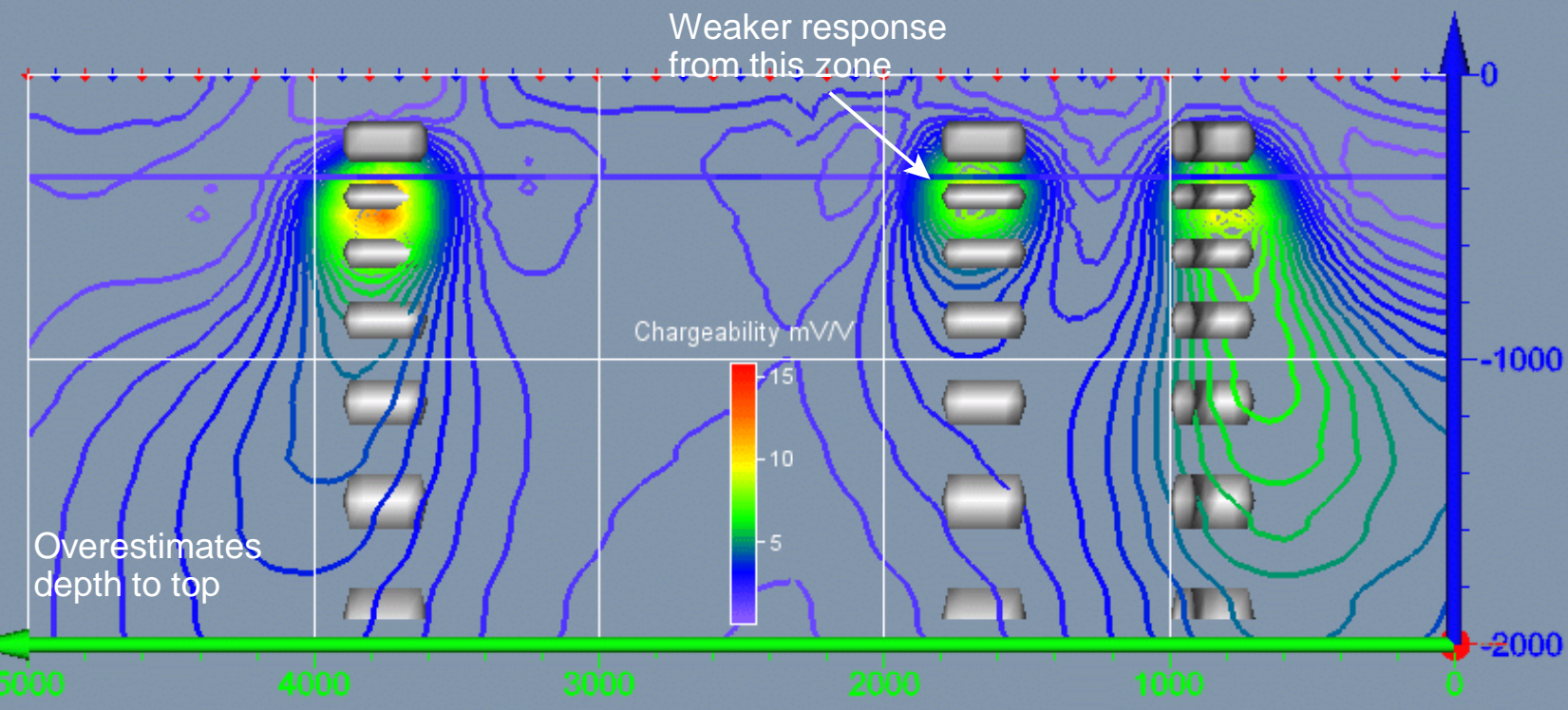

Bent long section view of contours through body centres



Consultant's Premium Selection

2.5D QUAD OFFSET DIPOLE-DIPOLE

100m dipole spacing, 200m line spacing, 4 lines of 20 electrodes active each reading

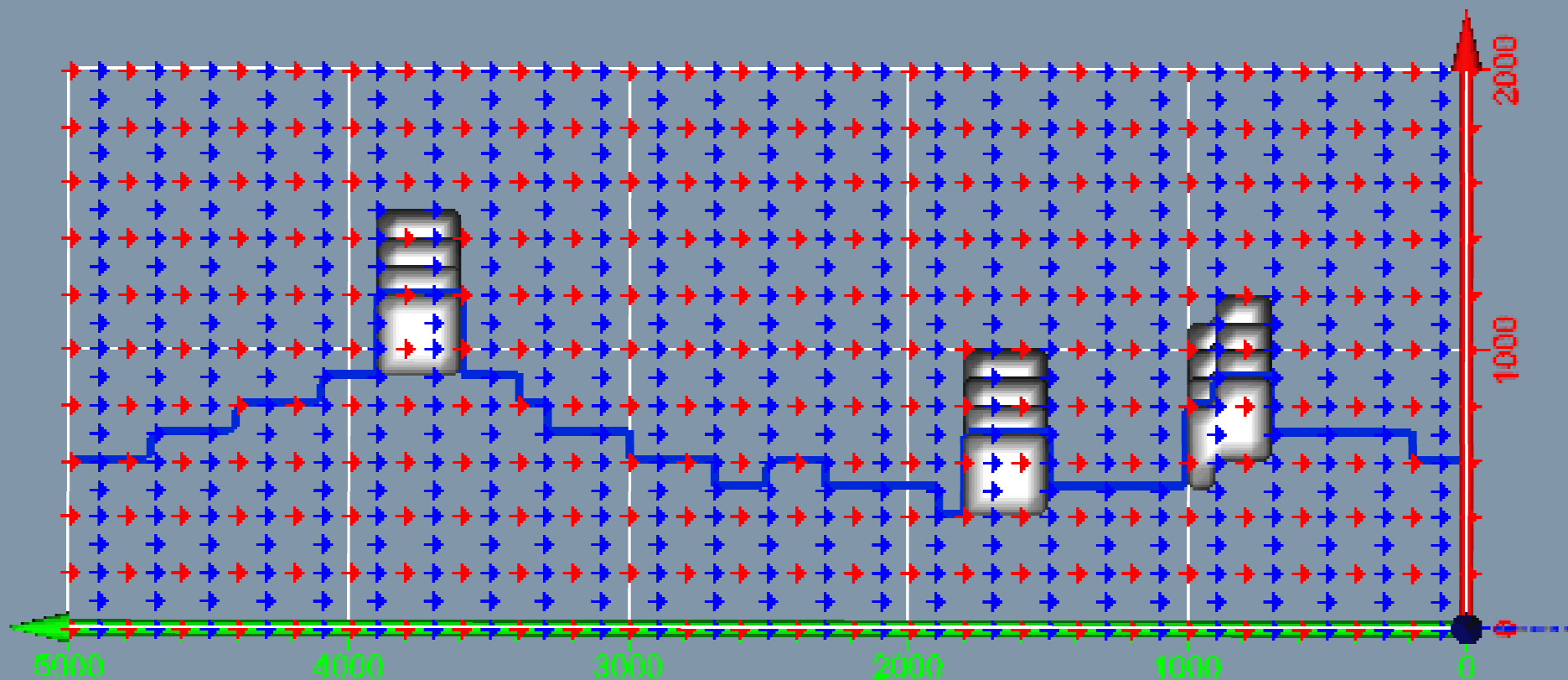

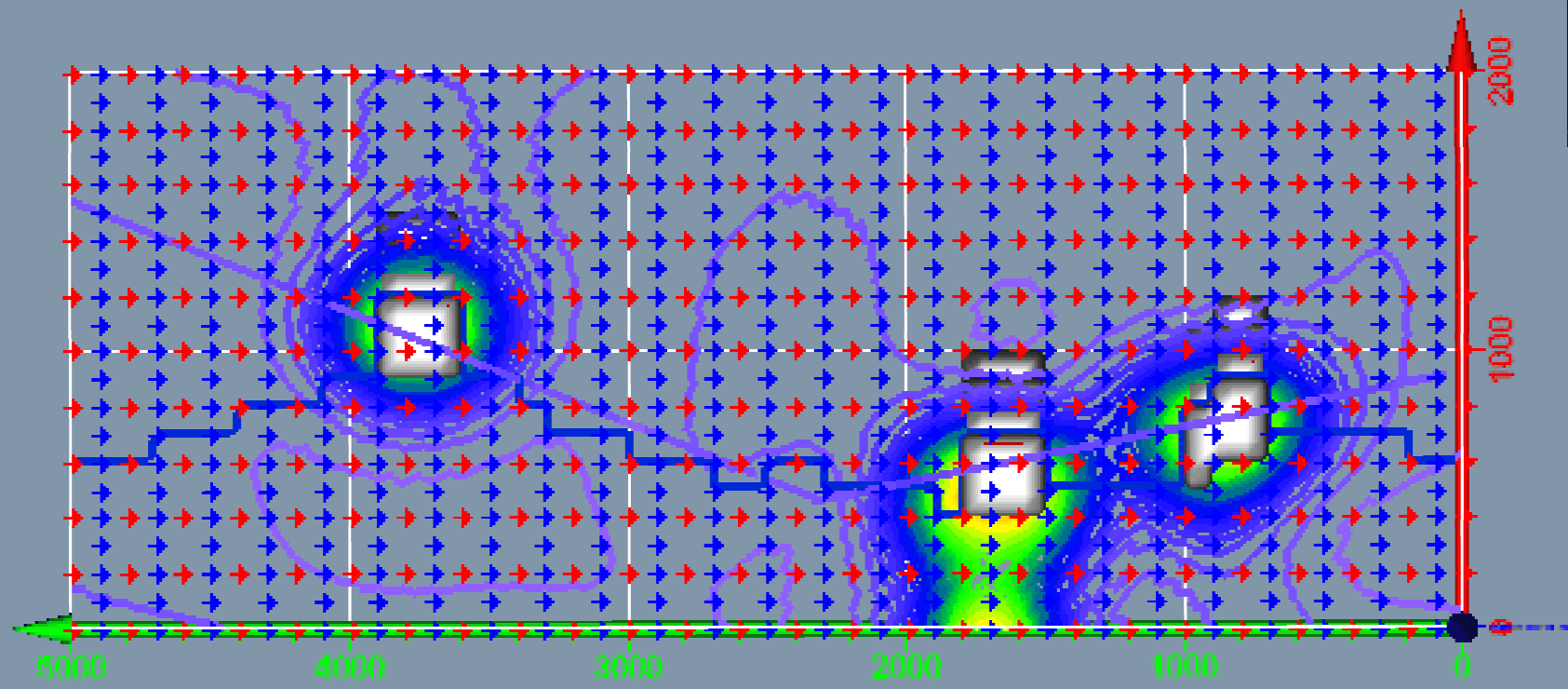

Plan view of contour slice through maximum response

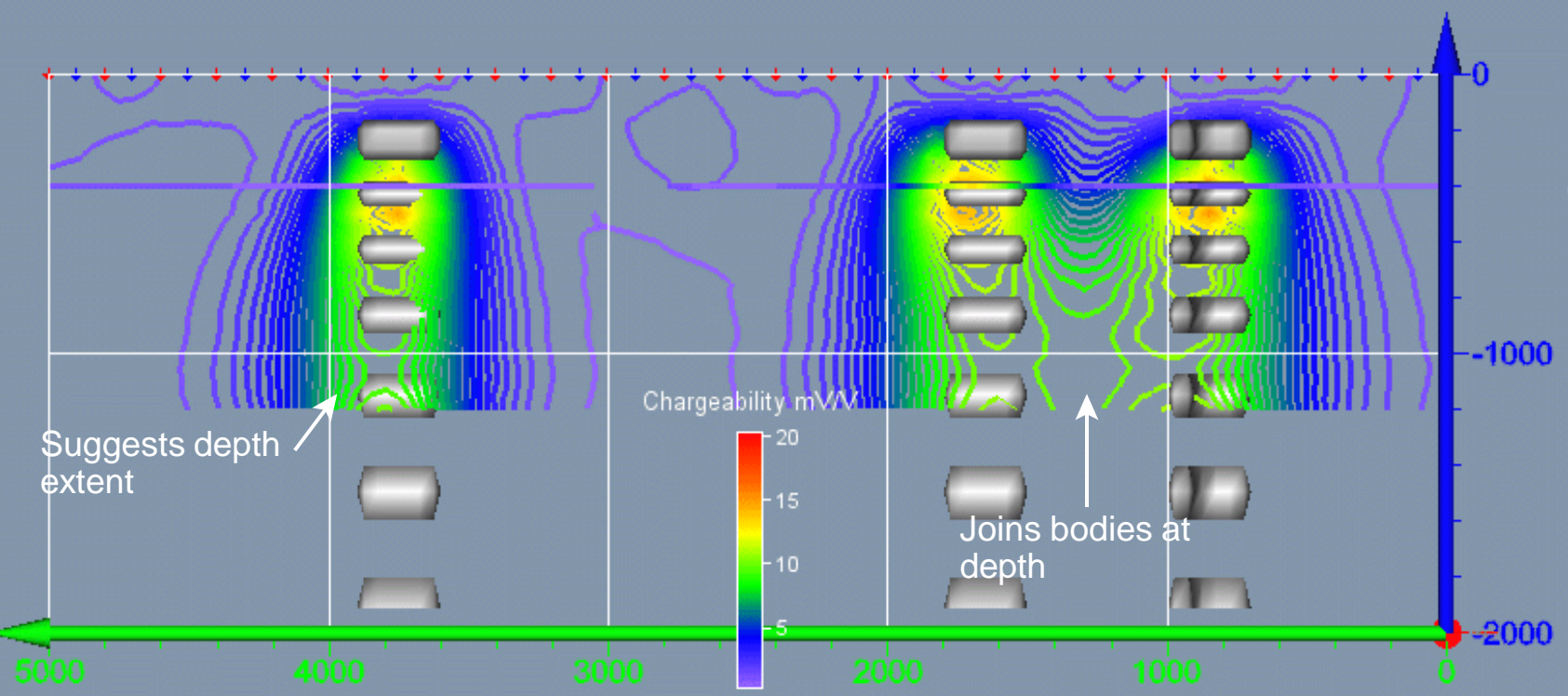

Bent long section view of contours through body centres



CFO's Premium Selection

2D DIPOLE-DIPOLE

100m dipole spacing, 500m line spacing, all 20 electrodes active each reading
Note: No bodies lie under any of the lines!!!

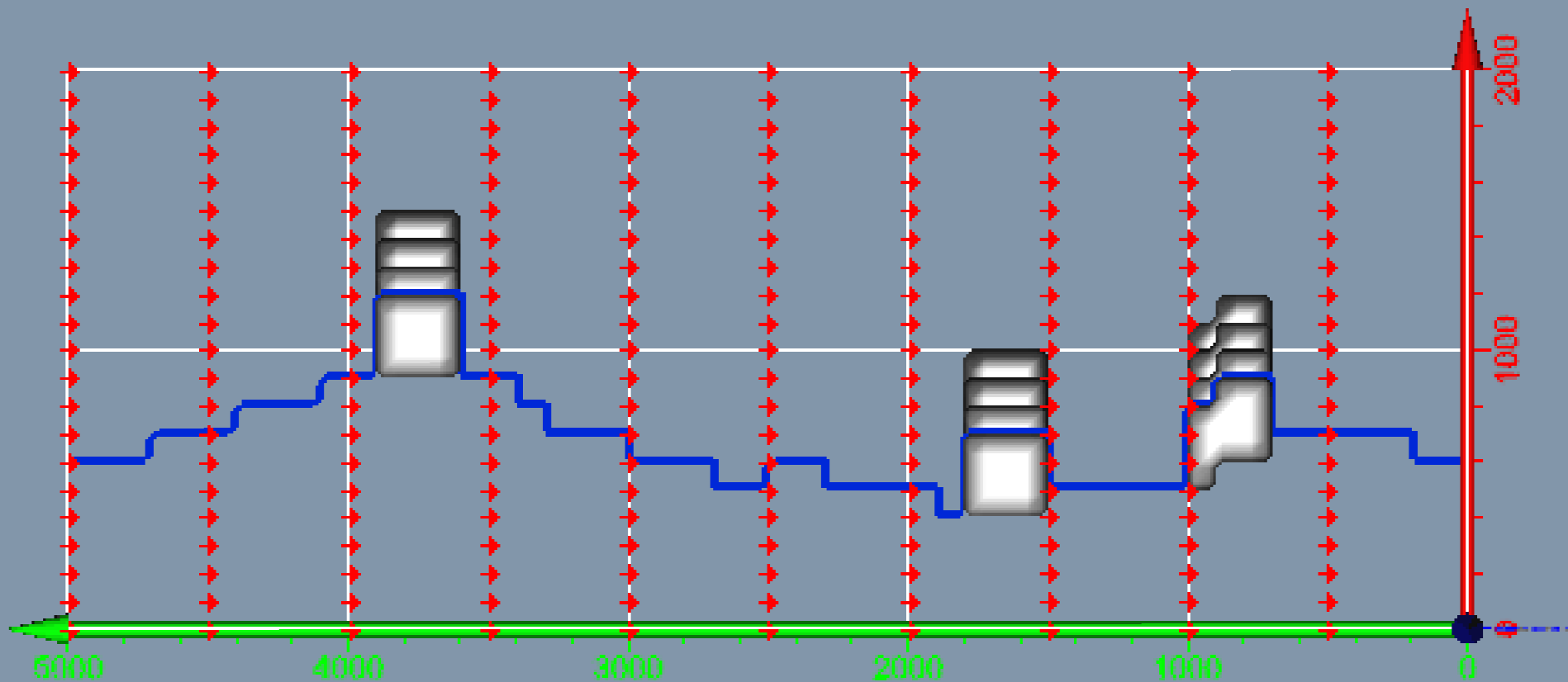

Broadside effects with 2D

Stacked 2D inversions - where would you drill?

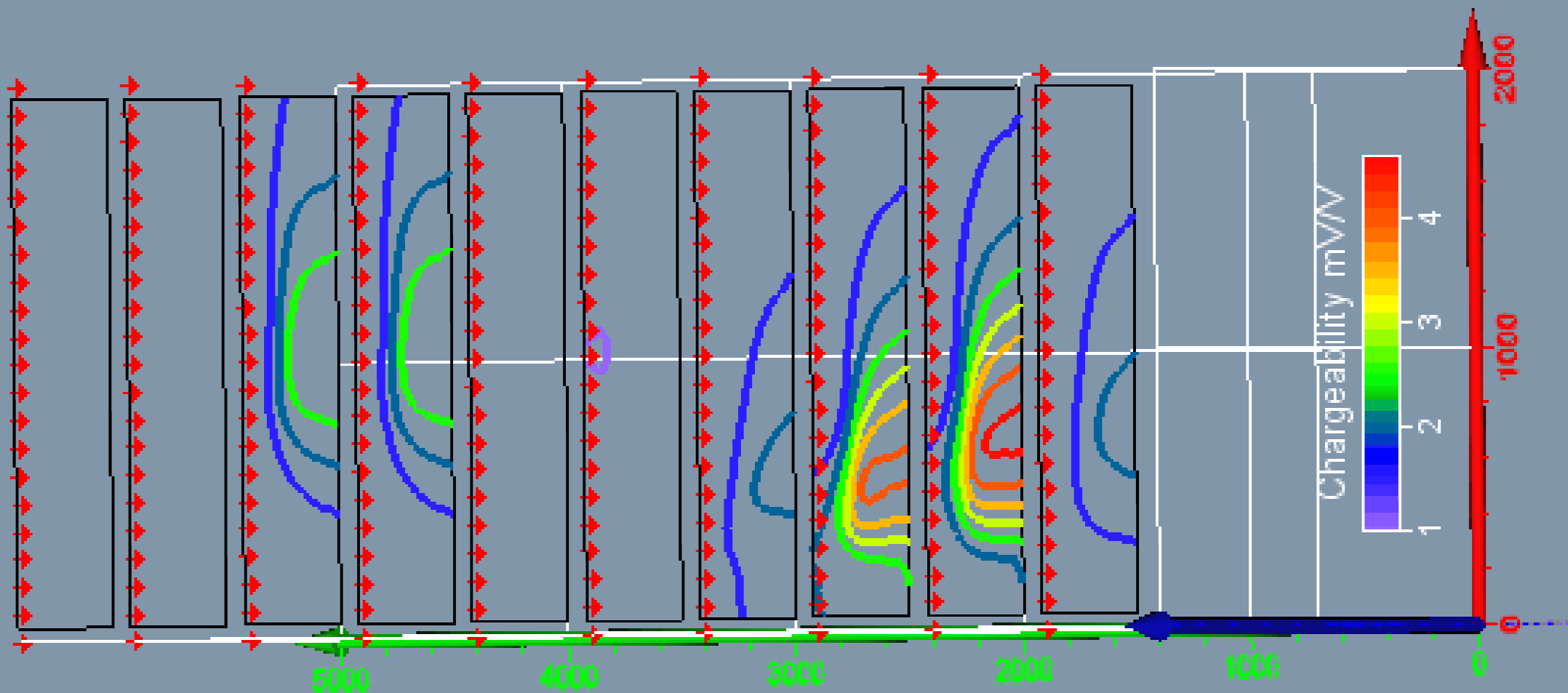

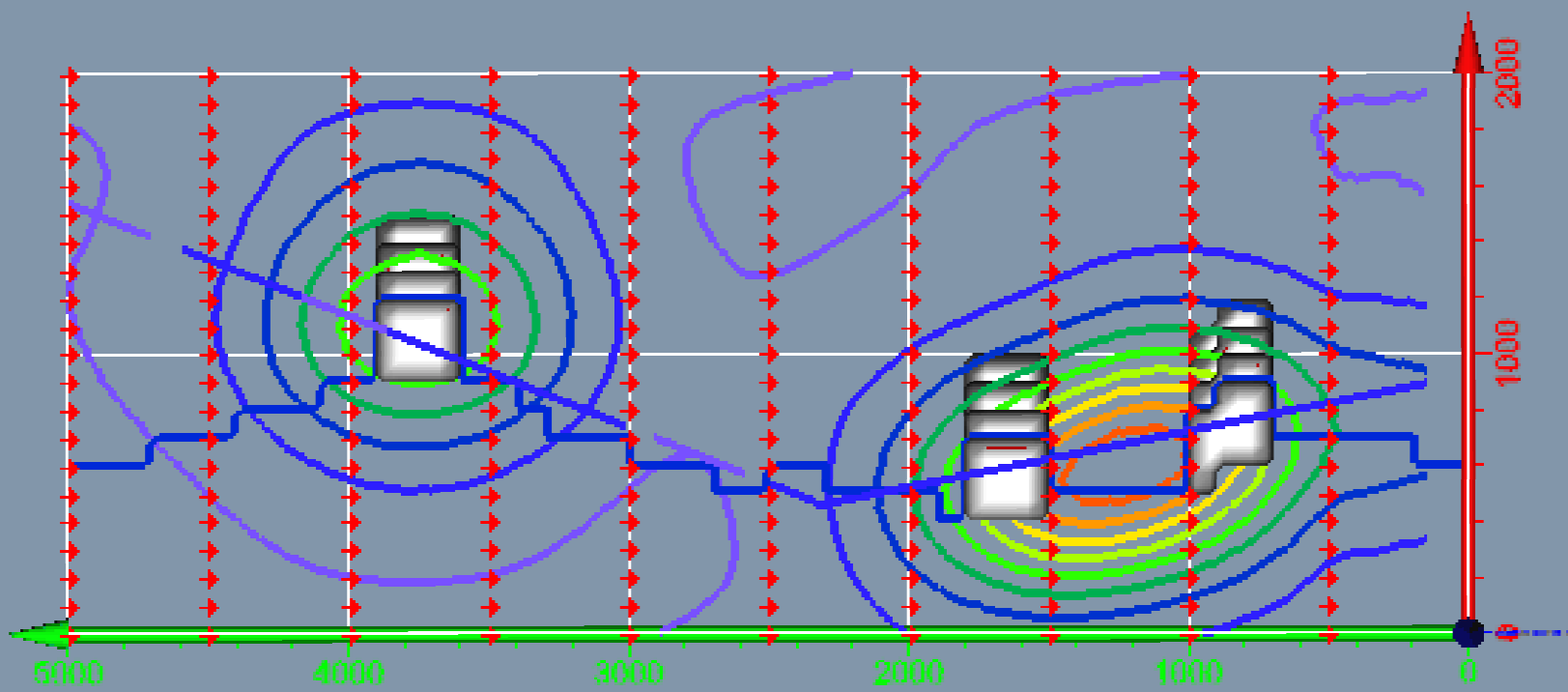

3D inversion - Plan view of contour slice through maximum response

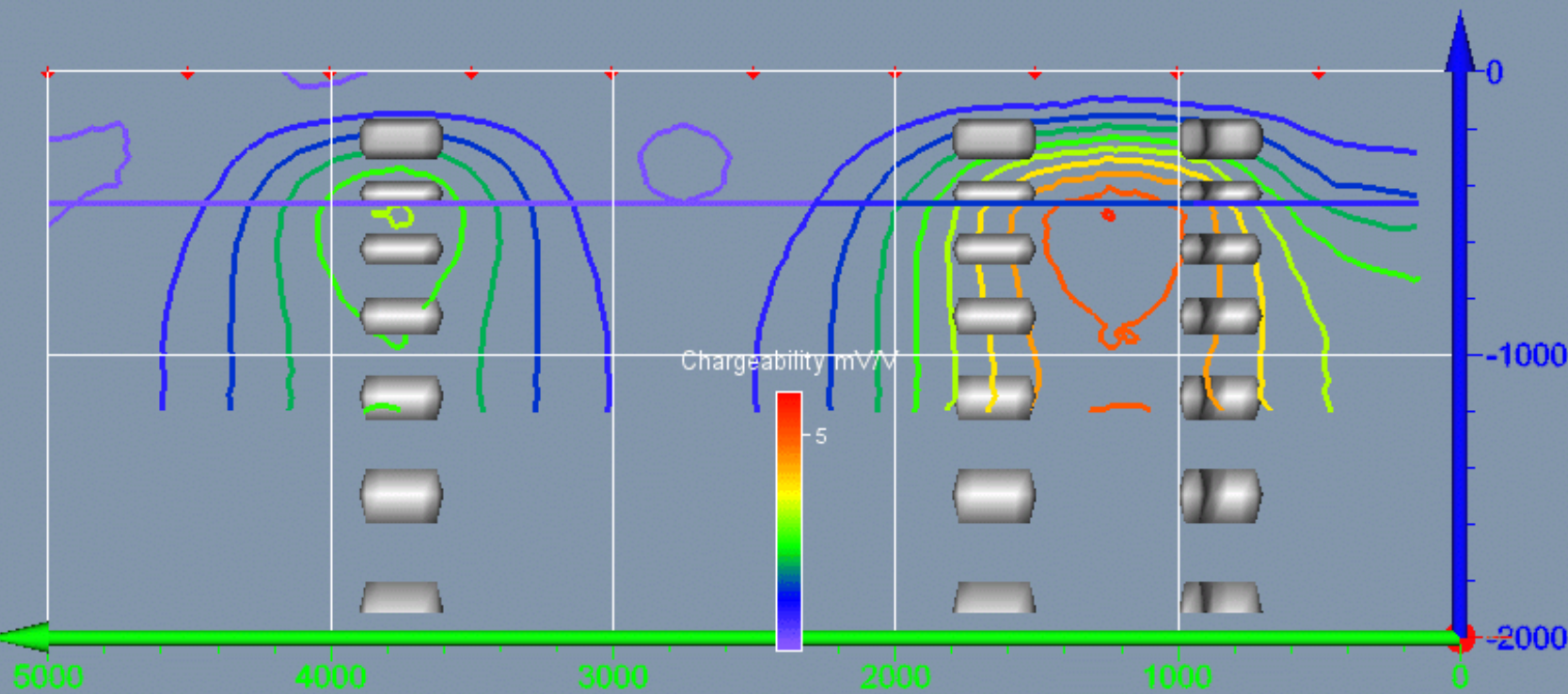

3D inversion - Bent long section view of contours through body centres

Drilling on section would only lead to tears. Drilling the bull's eyes would only get one of three bodies.

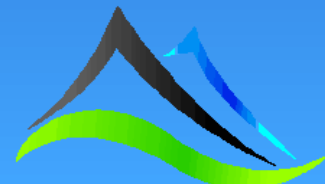

Consultant's fallback position

Along strike 2.5D offset dipole-dipole

100m dipole spacing, 200m line spacing, two lines each of 16 electrodes active each reading

Current will probably channel into the fault but this can be an advantage if the mineralisation is in contact with the fault

Mineralisation only occurs on this side of the fault. Fault is visible from space

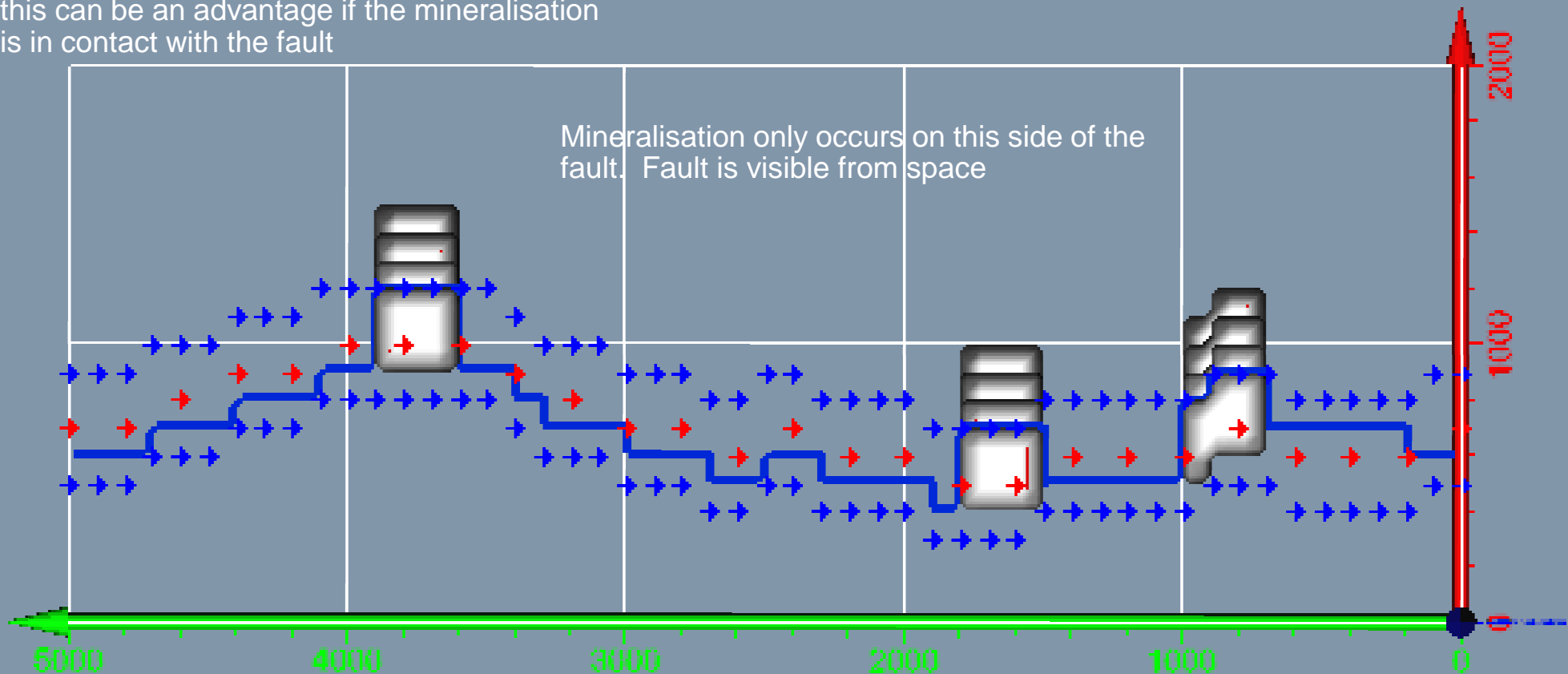

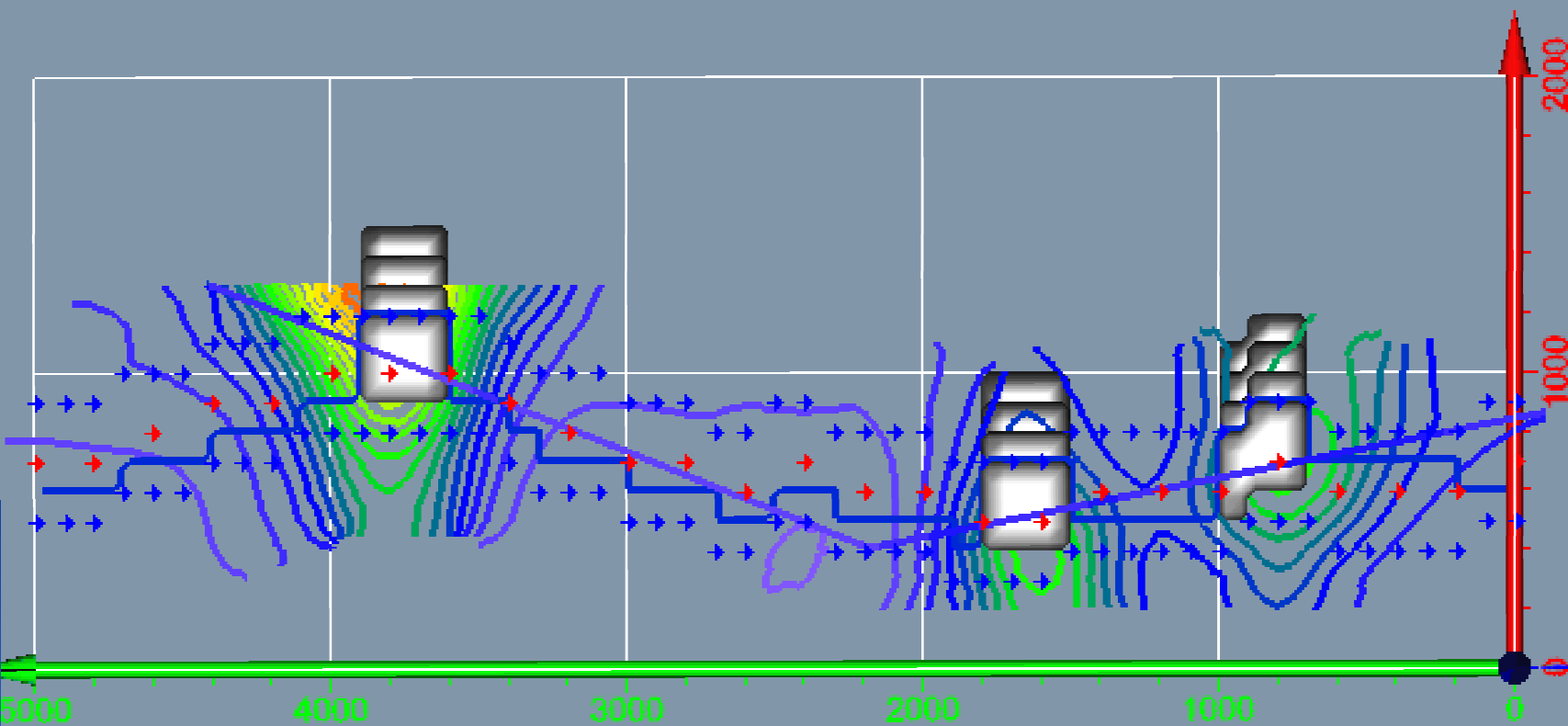

3D inversion - Plan view of contour slice through maximum response

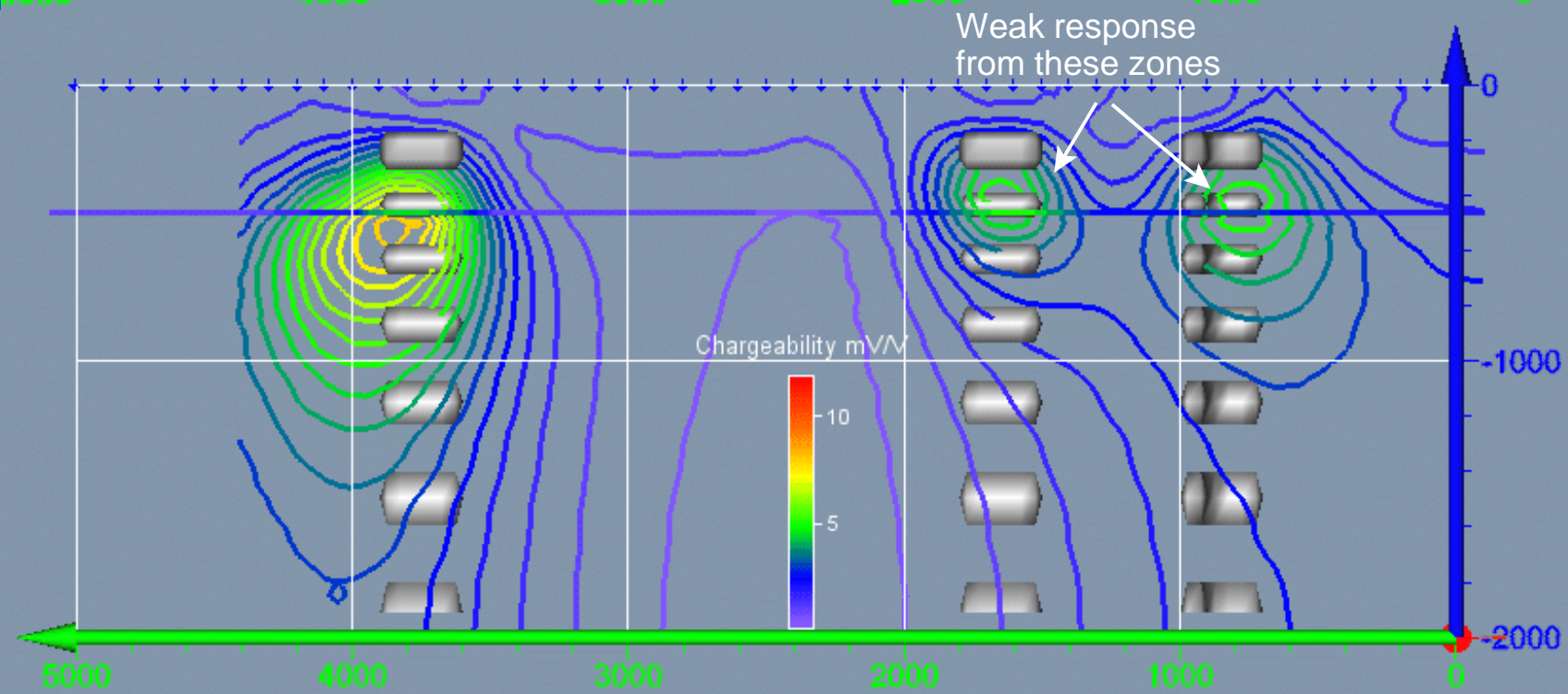

3D inversion - Bent long section view of contours through body centres

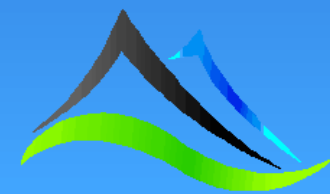

Conclusions

- The 2D Dipole Dipole combines the two close mineralised zones and may lead to barren holes
- 2D Dipole Dipole at wide line spacings is asking for trouble
- In this comparison the parallel to strike double offset dipole-dipole survey would have cost the least and still delivered good results.
- Things become even more complicated when we start pushing the middle zone down!
Another story for another day!

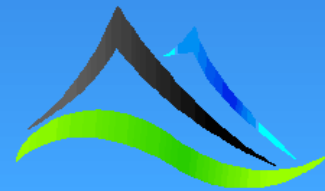

What we have learned so far

- Relegate 2D to history along with the fax machine and log tables, 2.5D offers a better result at a lower cost
- **WARNING!** - Equipment or arrays named after gods, mythical beings or inclement weather may not have similar performance to their namesakes.
- Time spent modelling up front can save you money and improve your chances of success
- We still have some way to go in finding the best array



Acknowledgements

Rio Tinto

For supporting this modelling

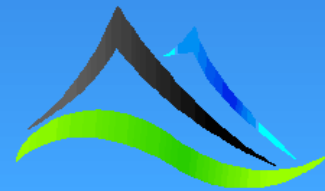

Appendix

For the technical minded

And other bits I could not fit into 25 minutes!

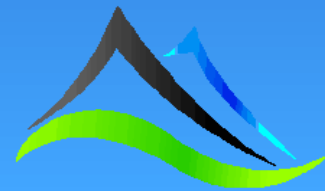

Case Study 1 - Forward Modelling Details

Forward modelling was undertaken using Res3Dmodx64 routine developed by Meng Heng Loke

The mesh consisted of 50m x 50m voxels over a 21000m x 2000m area with 13 layers increasing logarithmically in thickness from 50m to 2162m to achieve a maximum depth of 6487m. All electrodes (current and potential) were included in the mesh. The mesh size was 420 x 40 x 13

Continues at
50m spacing
to 0m

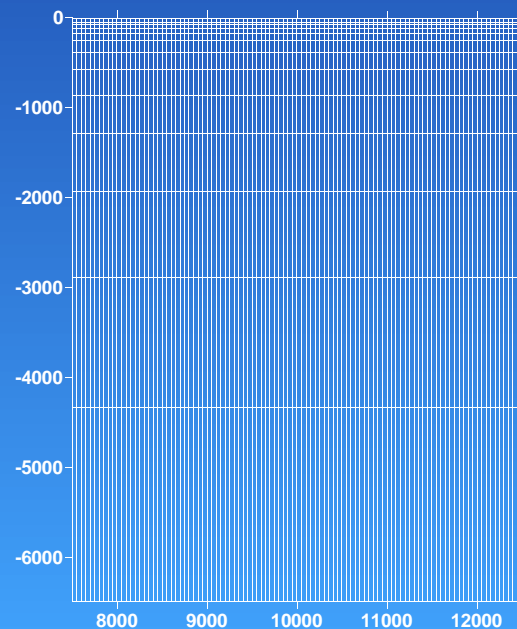

Continues at
50m spacing
to 21000m

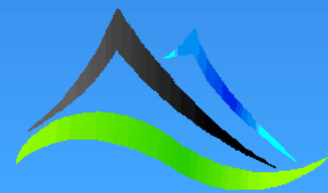

How we added Noise

Noise was added to the forward modelled primary voltage as follows:

If $V_p > 0.1$ mV

$$V_{p(\text{noise})} = V_p + RN * V_p * 0.1$$

If $V_p \leq 0.1$ mV

$$V_{p(\text{noise})} = V_p + RN * 0.1$$

RN = Random number between -0.5 and +0.5



How we added noise to m

The apparent resistivity was then recalculated.

The chargeability had noise added proportionally to the noise in the primary voltage.

$$m_{(\text{noise})} = m * Vp_{(\text{noise})} / Vp$$

The noise adjusted apparent resistivity and chargeability were input to Res3DinvX64 after clipping the data to $Vp_{(\text{noise})} > 0.1 \text{ mV}$

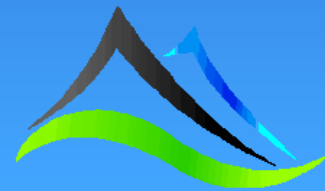

Specs - Case study 1

Expanding gradient - 100m potential electrode spacing, 6500m to 21000m Tx dipoles.

3D Pole-dipole - 200m potential electrode spacing with active current electrode in the centre of a 2 dipole x 2 dipole square and remote at 10 km.

Offset Dipole-Dipole - 100m Rx dipoles, 200m Tx dipoles

All sections are along line 1000 over the top of the body and use linear colour stretch applied to the section being displayed with 0.5 mV/V linear contours



Why arrays see different things

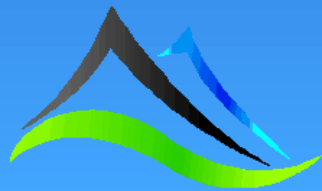

SENSITIVITY

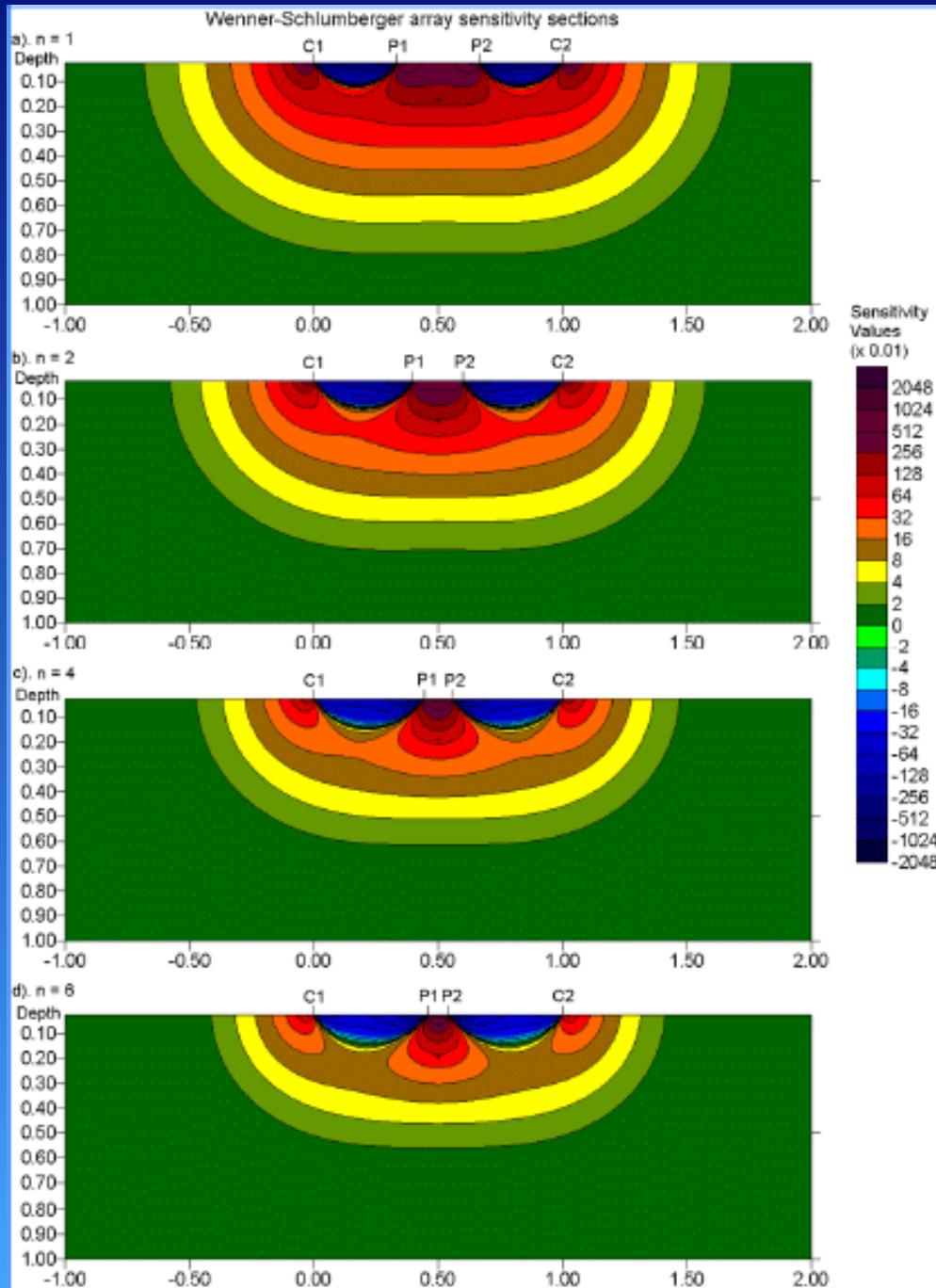

Wenner/Schlumberger/Gradient array
Change in sensitivity for changing
MN with constant AB

← Note negative sensitivity areas

Reasonable sensitivity maxima at $\sim 3 \times$ MN for
long AB

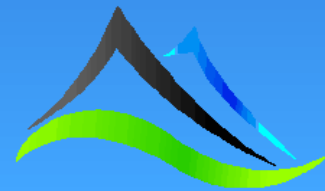

SENSITIVITY

n

1

2

4

6

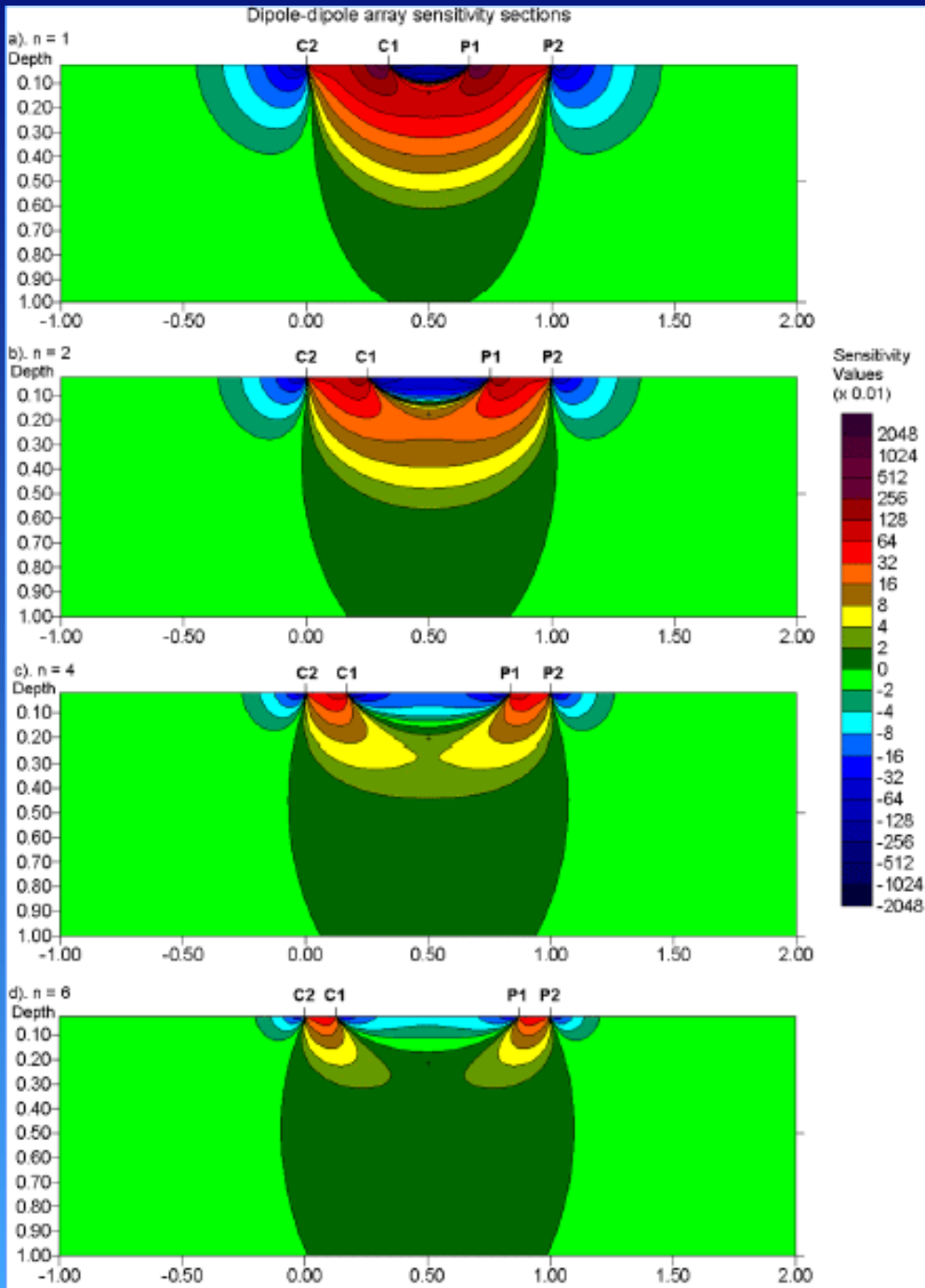

Dipole-dipole array
Change in sensitivity for changing “n”
value

For dipole-dipole array the median
depth derived from the sensitivity
function is likely to underestimate the
true depth of investigation by 20-
30%

Reasonable sensitivity maxima at $\sim 3 \times MN$ or
AB for large n but under the dipole NOT
between them



SENSITIVITY

n

1

2

4

6

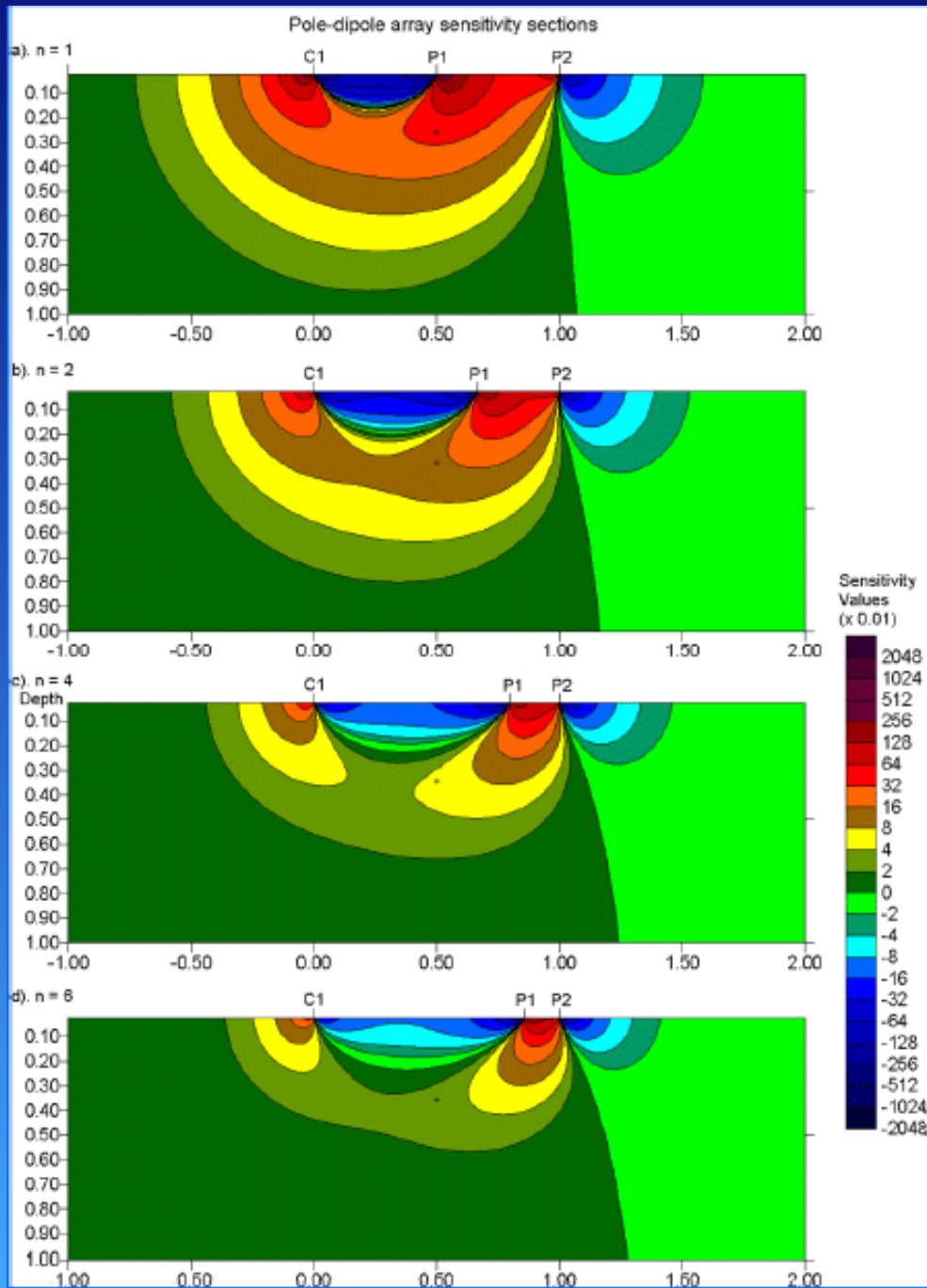

Pole-dipole array
Change in sensitivity for changing “n”
value

Reasonable sensitivity maxima at $\sim 3 \times MN$ for large n but under the dipole NOT between the current and potential electrodes

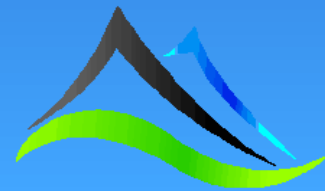

Using Sensitivity to our advantage

Examples of Quad Offset array processing
4 inline and 12 cross line (Herringbone)
dipoles

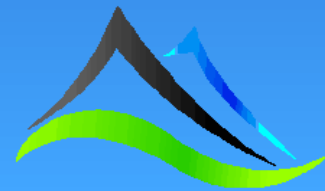

Scale it up

- Quad offset array
- Multiple MN spacings acquired from the same electrodes at the same time
- Multiple AB spacings by reusing pits
- Measure both along line and cross line dipoles

100m electrode spacing and 200m Rx line spacing
delivering 100m, 200m 300m and 400m in line and 200, 400, 600m cross line
Rx dipoles acquired simultaneously from readings using 200m and 800m Tx
dipoles

Extra data provided post acquisition
by processing, no additional survey
cost

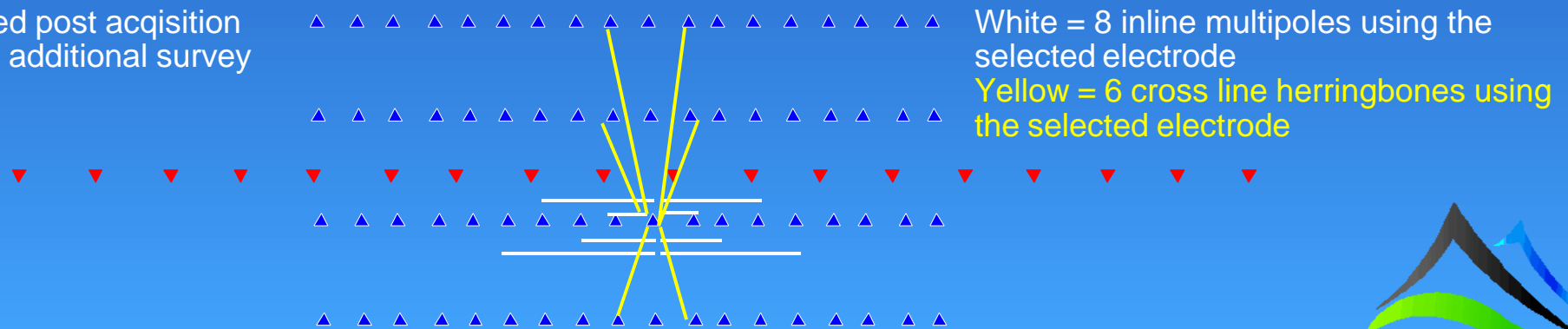

Vary the depth to top

3D Multipole array

In-line Multipoles only - no Herrinbone

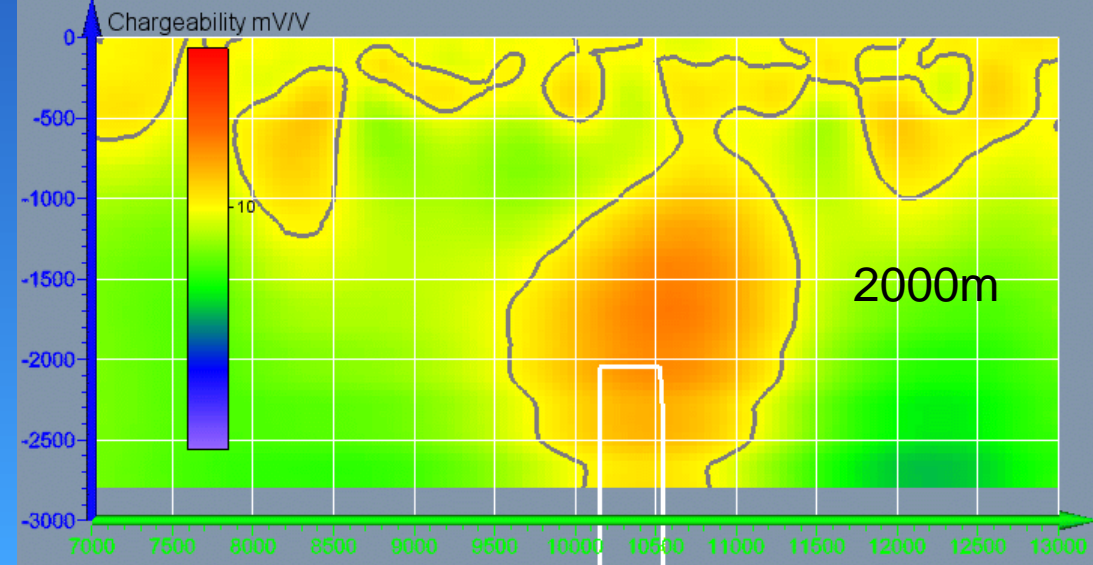
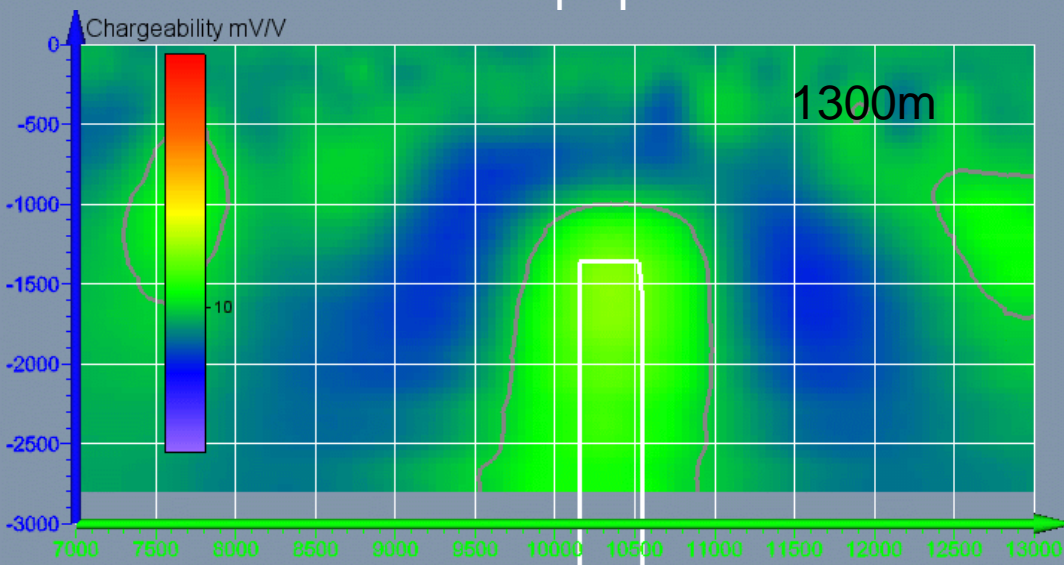
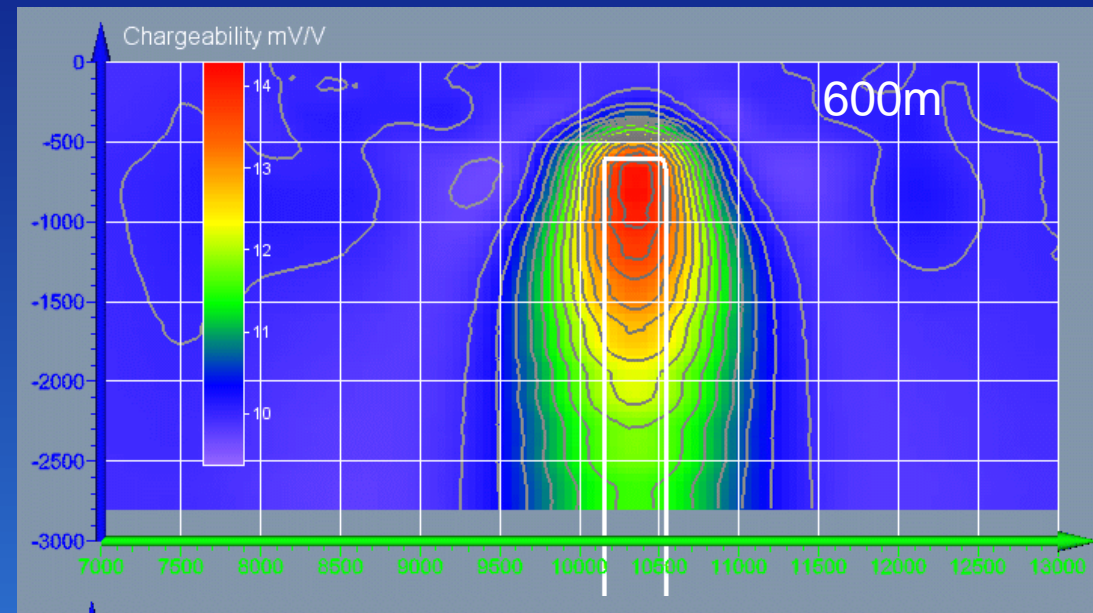
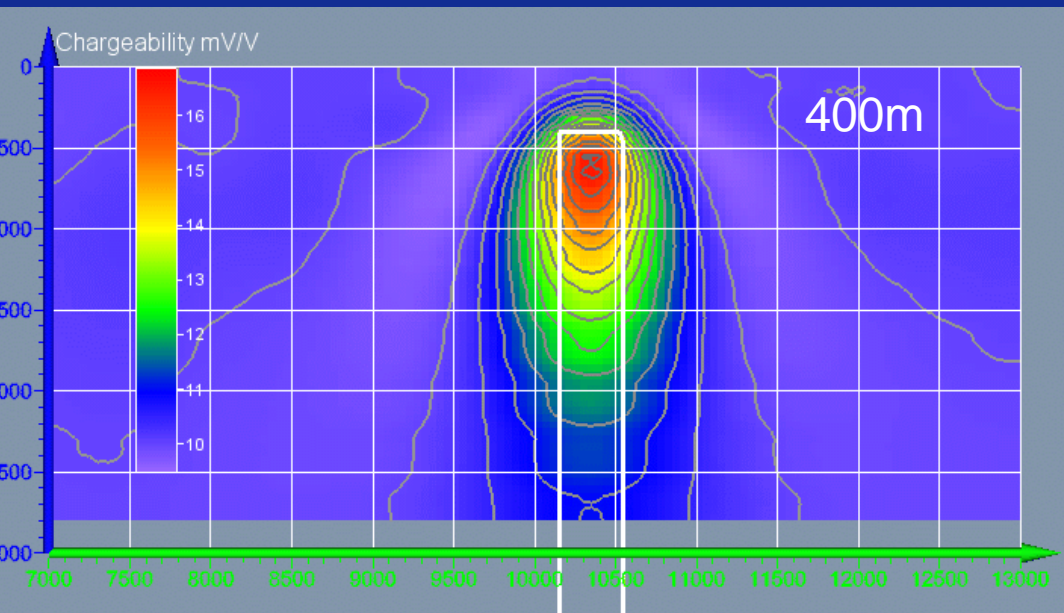

Vary the depth to bottom

3D Multipole array

In-line Multipoles only - no Herrinbone

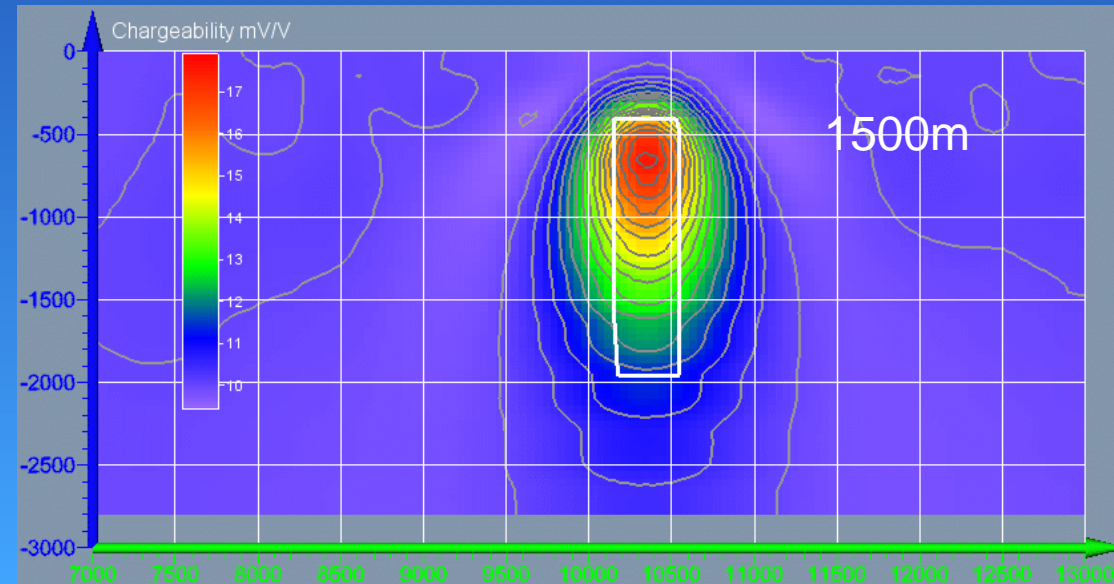
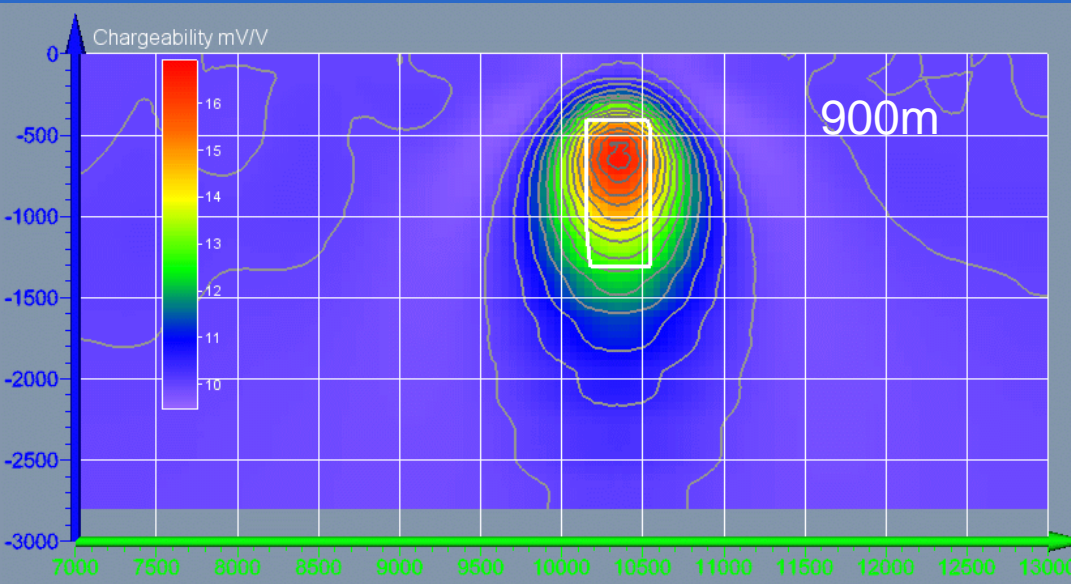
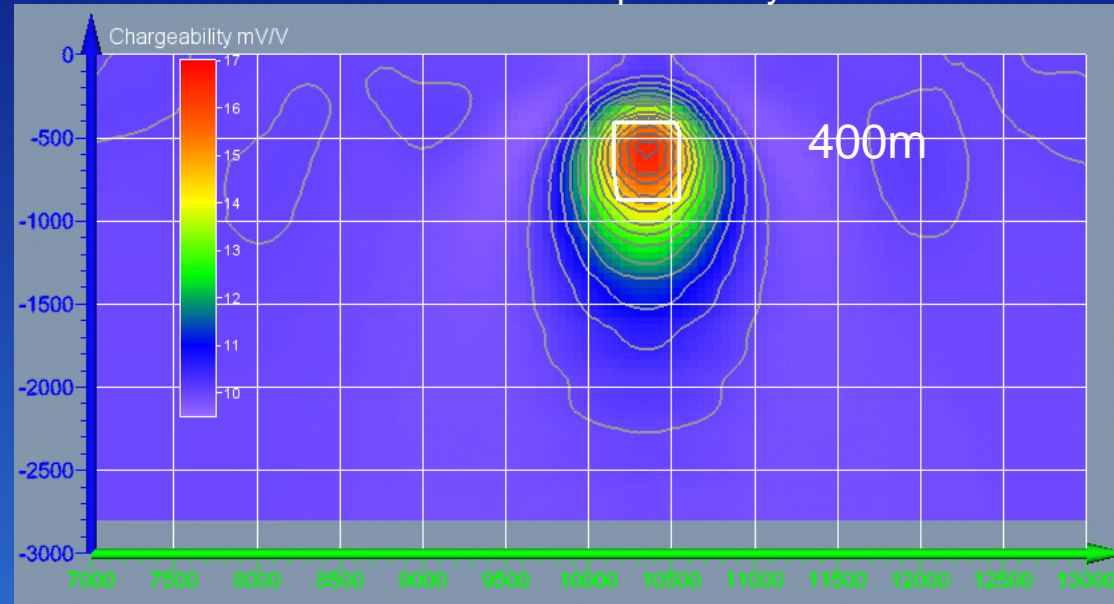
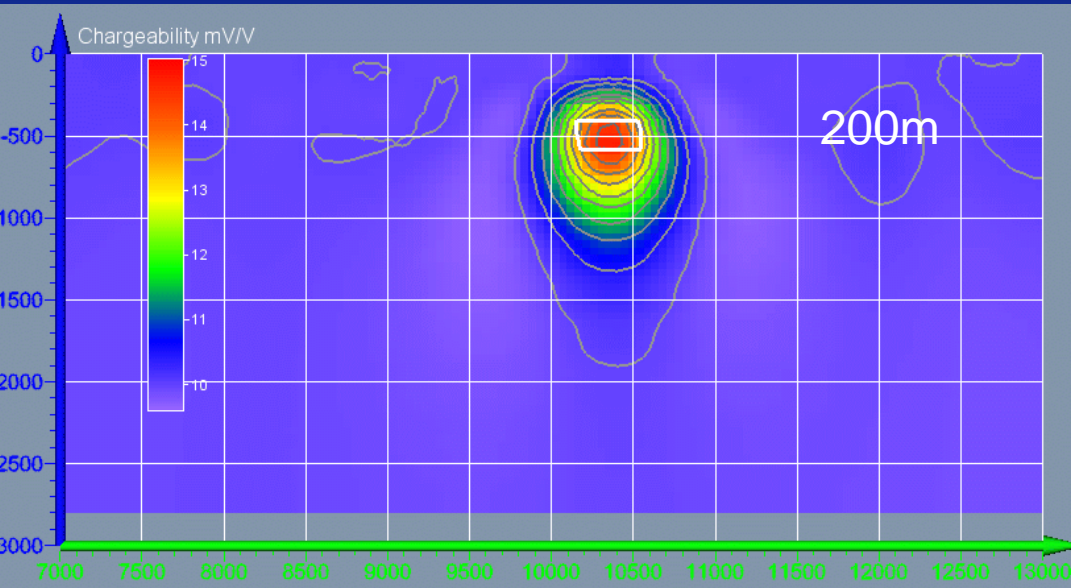

Vary the distance below a screen

3D Multipole array

In-line Multipoles and Herrinbone used

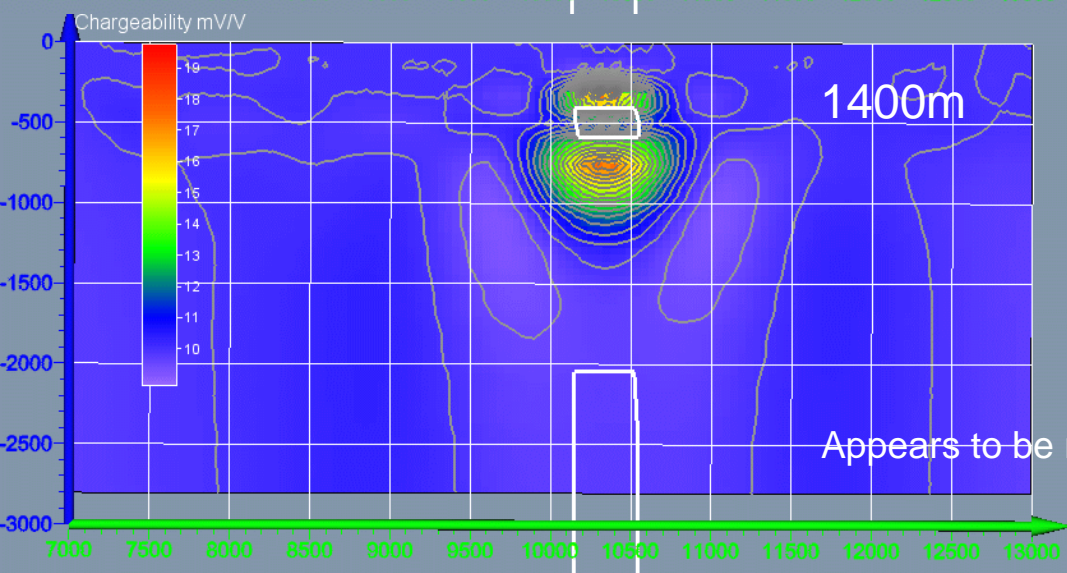
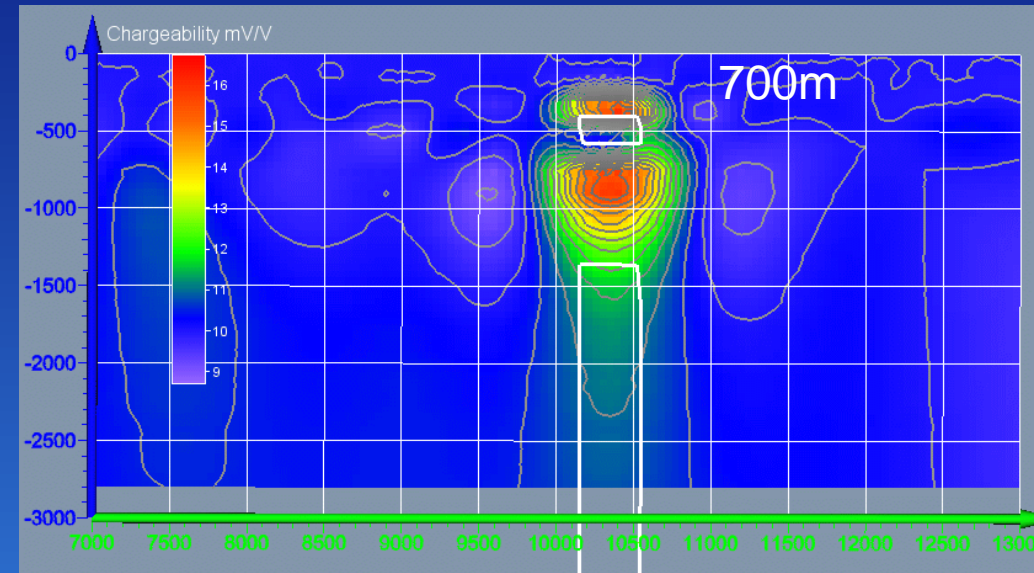
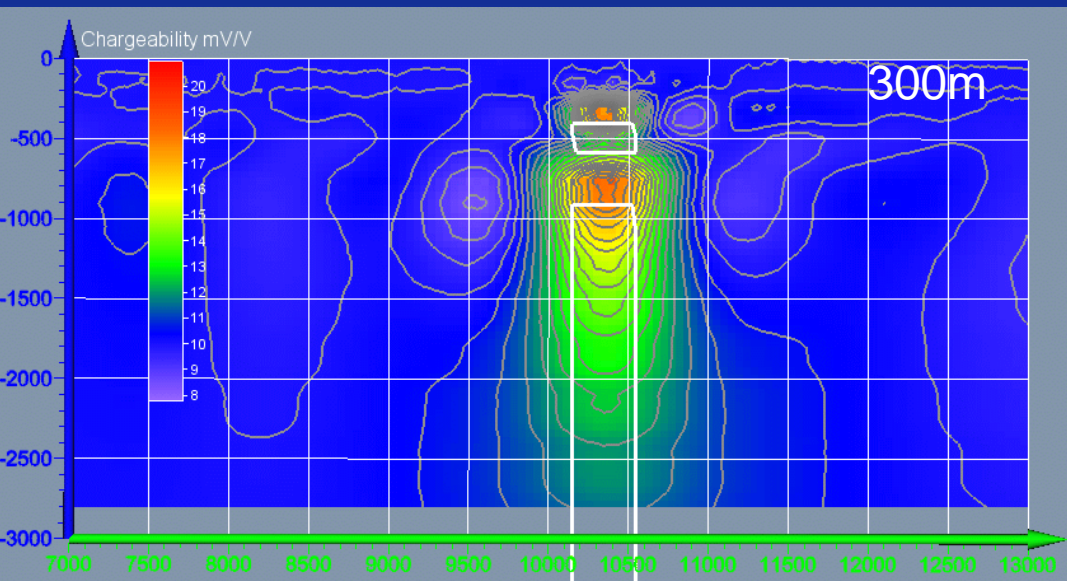

Mapping dip

Body dips to the left

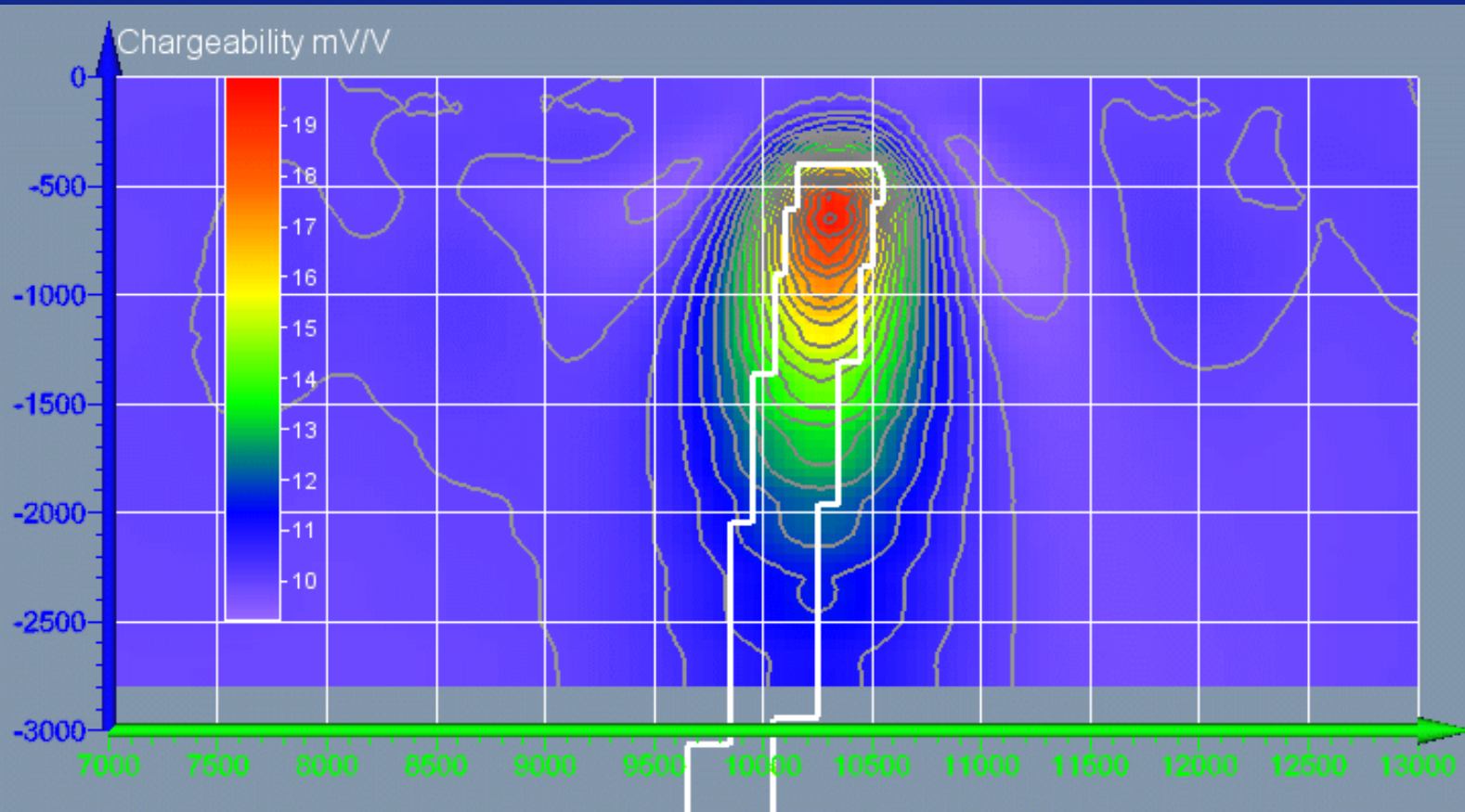

In-line Multipoles only
- no Herrinbone

Subtle dip response
relative to none on
previous arrays



Conclusions

We are not quite there yet but by adding dipoles at different spacing and orientation we can change the resolution without an increase in survey cost or time. The processing time however more than doubles and speeding this up is worthwhile. Finding the right match of dipole sizes and orientations will be the key.



Real Case Study



Porphyry targeting in Mongolia - 50 km² area

Quad Offset dipole dipole array

200m Rx electrodes giving 200m, 400m, 600m and 800m Rx dipoles

400m Tx electrodes using 400m and 1200m dipoles

50 kVA transmitter injecting an average of 21A for the survey (6.6 to 66A)

1163 electrodes, 750,000 readings distilling to 230,000 readings after editing bad points and averaging repeats.

6 weeks to acquire - \$600k all up including mob/demob of 2 tonnes of equipment from Australia and interpretation

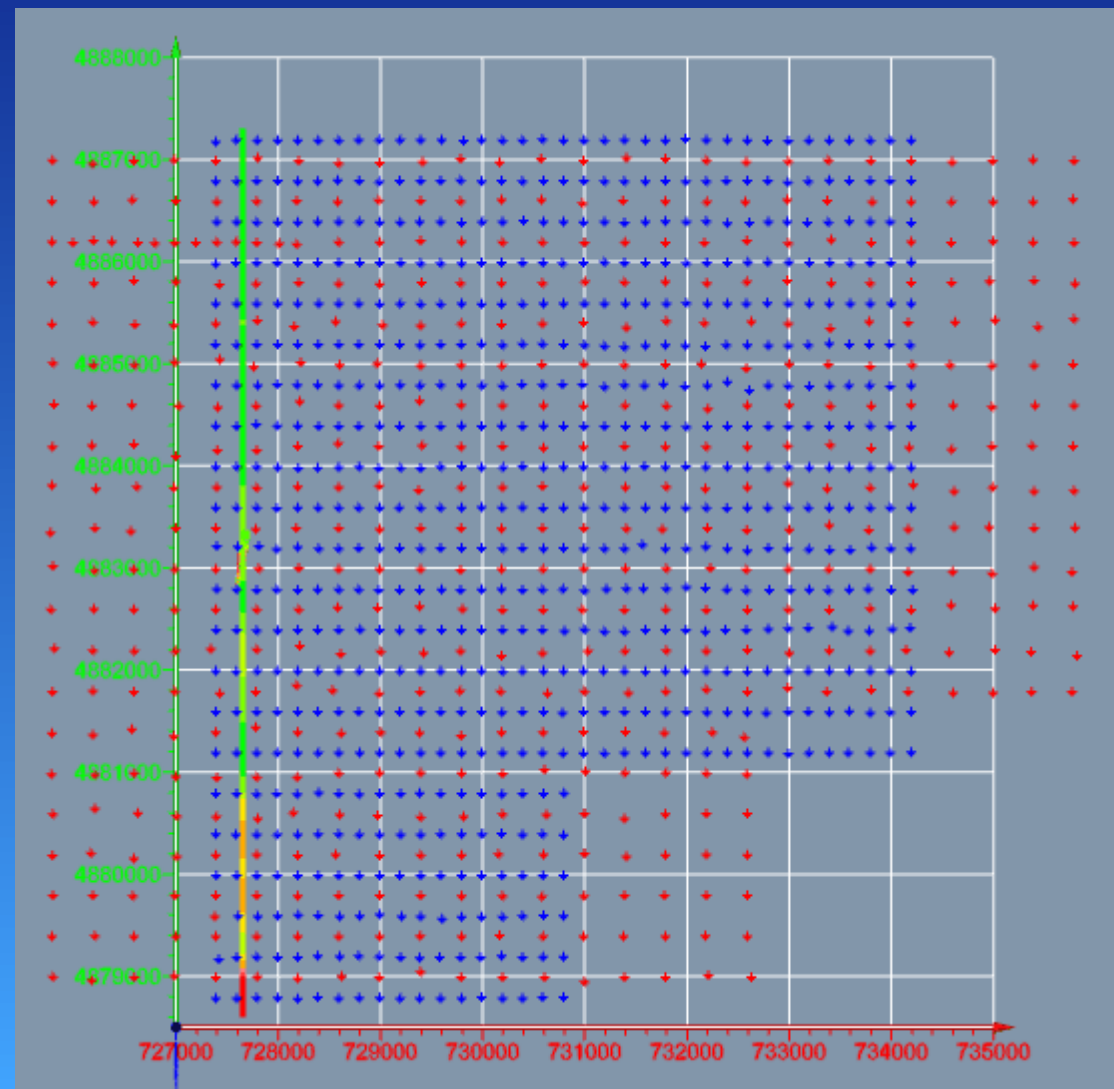
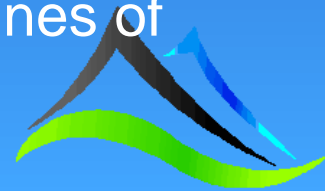

Case Study

Comparison between IP and Cu grades in the deepest drillhole

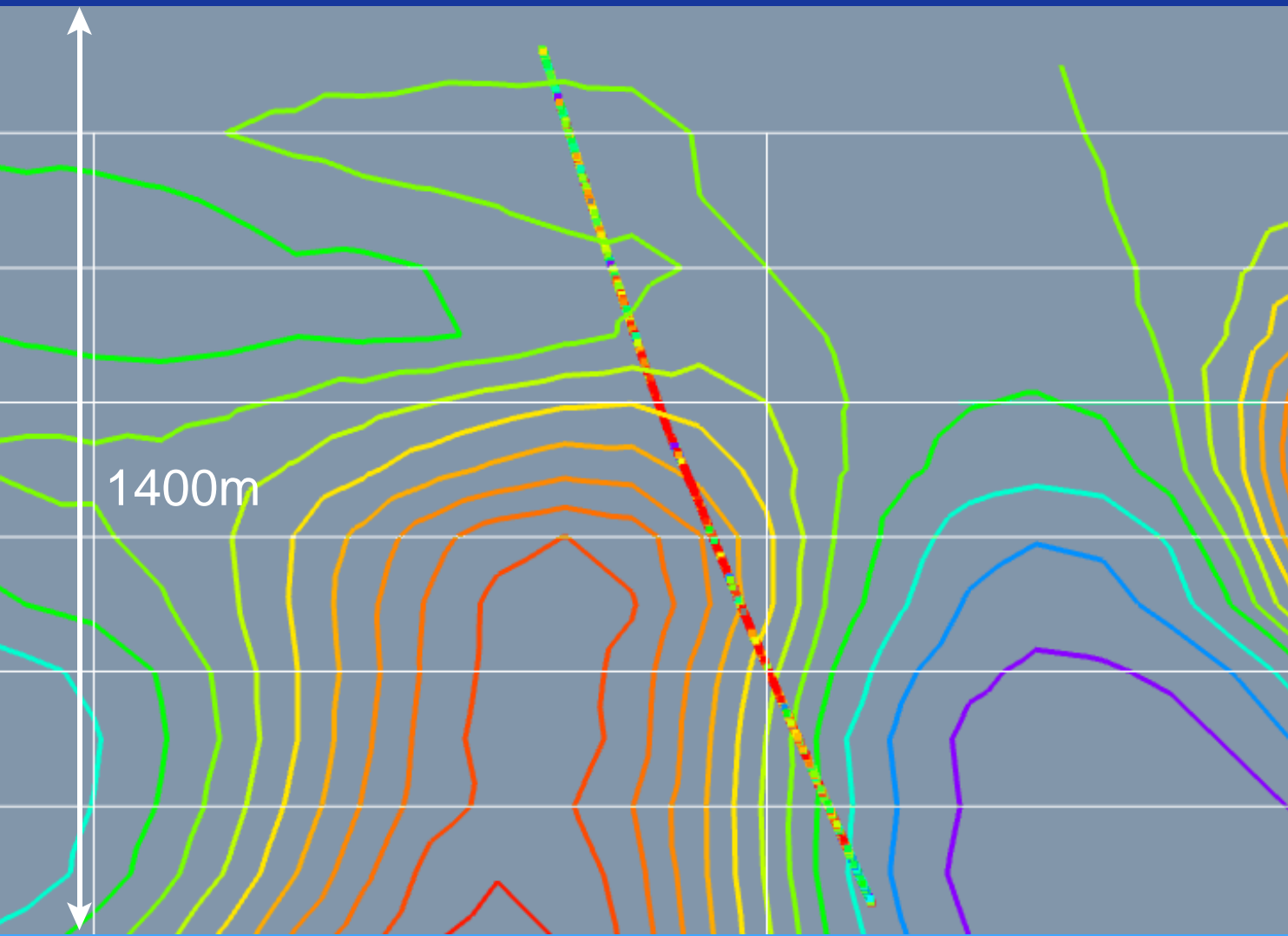

2 mV/V contours of chargeability

Cu to 3.3%

Resistivity 100 -1000 Ohm m in this location

Good correlation to at least 1km depth

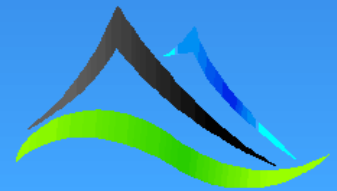

Specs - Case study 2

3D Pole-dipole - remote 2 km to the west

Offset Dipole-Dipole - 100m Rx dipoles, 200m
Tx dipoles

All contours use linear colour stretch applied to
the data limits of that data set and 0.5 mV/V linear
contours



Consultant's Super Premium Selection

2.5D QUAD OFFSET DIPOLE-DIPOLE

100m dipole spacing, 200m line spacing, 4 lines of 20 electrodes active each reading - 4 multipoles

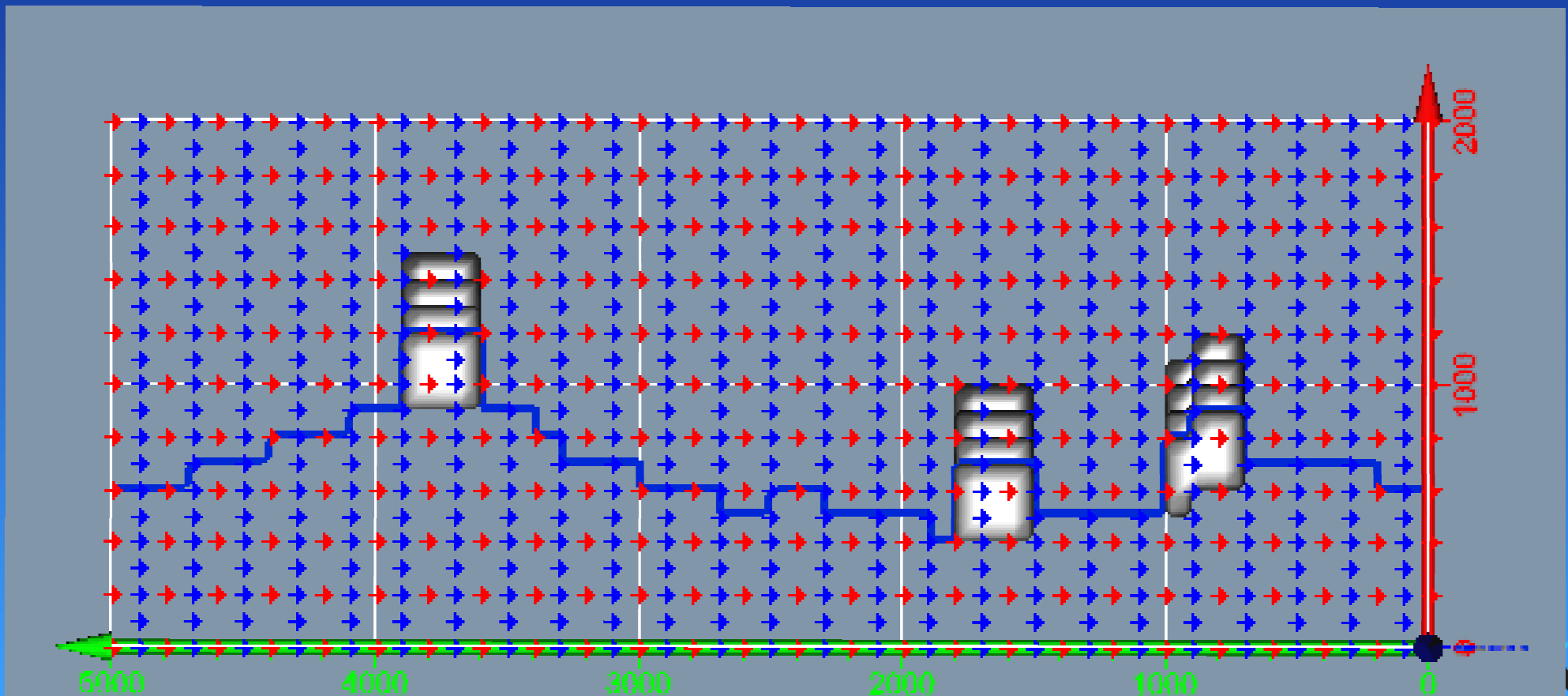

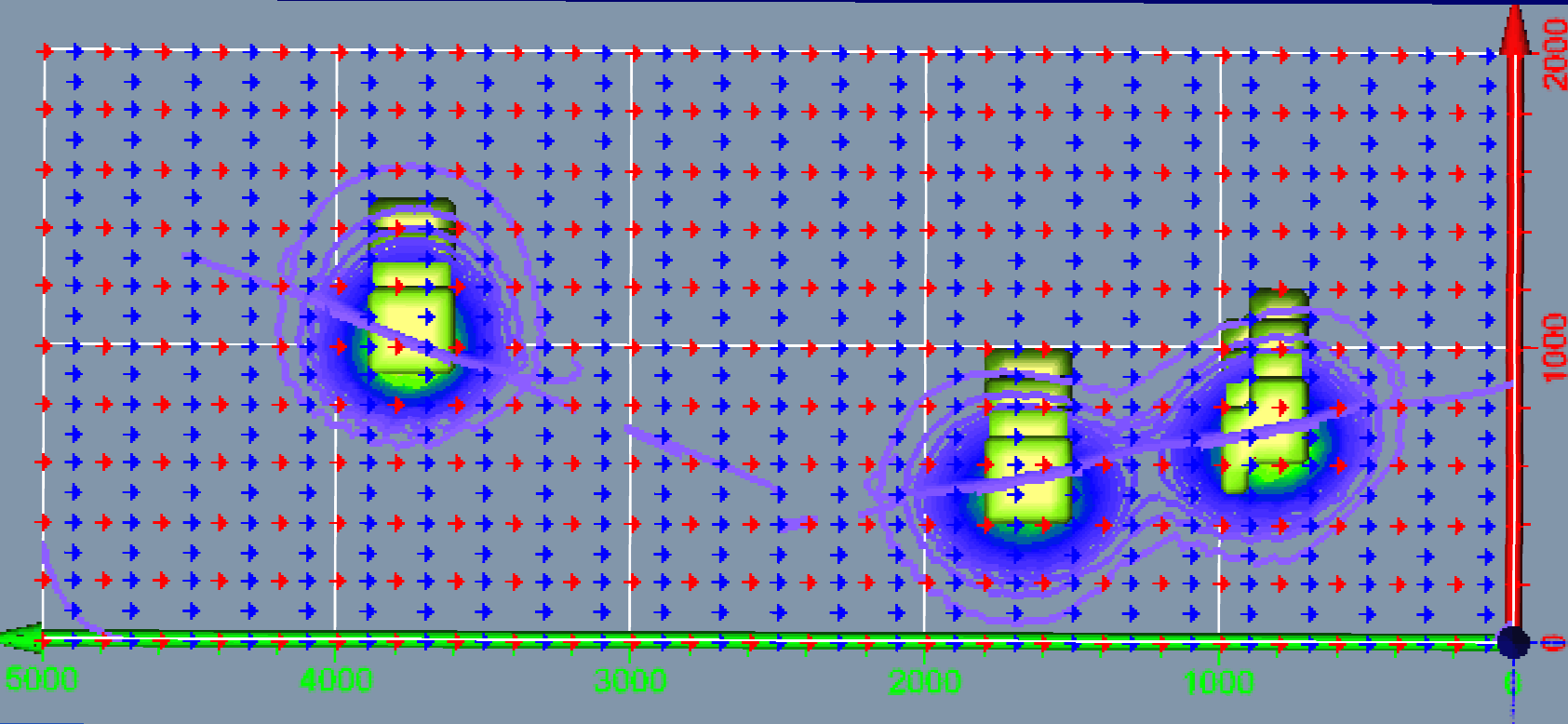

Plan view of contour slice through maximum response

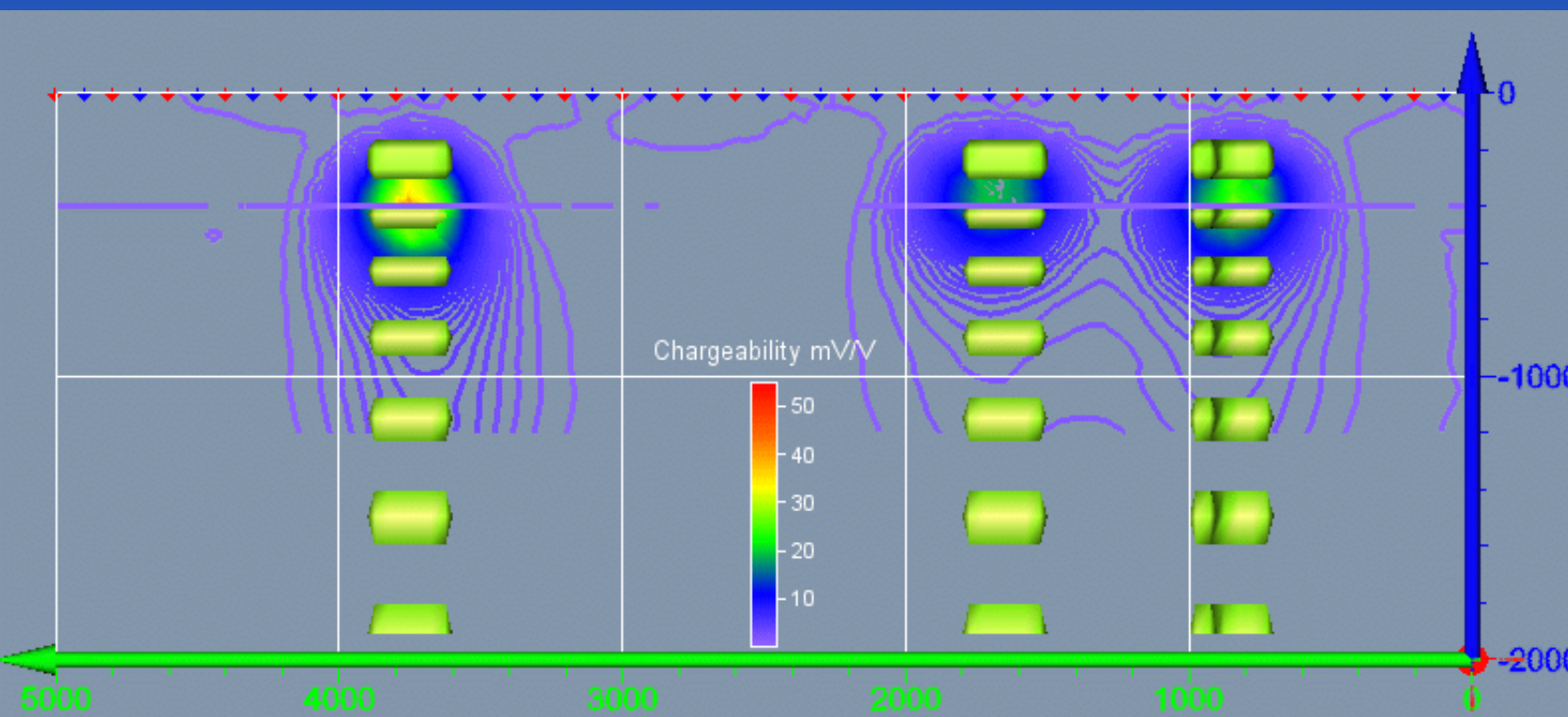

Bent long section view of contours through body centres

Adding Multipoles has increased the resolution.

